

SU4500

Barrier Optical Turnstile

The attractive SU4500 optical turnstile has clear motorized panels that provide bi-directional access control in a very compact installation footprint. Available options include a lighting package that allows users to customize illumination colors and transition lighting effects. For high end environments where space is at a premium, the SU4500 is a perfect fit.



COMMON APPLICATIONS

- Employee and Visitor Access Control
- Time and Attendance Integration
- Pedestrian traffic flow control

TYPICAL INSTALLATION SITES

- Government Facilities
- Corporate Lobbies
- Health/Recreation Centers



FUNCTION

The Supervisor 4500 provides bi-directional access control and other operational and passage modes (described below). In controlled passage mode, upon receipt of a valid card signal from an access control system, the motorized barriers of the turnstile open away from the user and allow a single user to pass through the turnstile in the requested direction. If an unauthorized user attempts to tailgate on the entry, the integrated sensors will recognize the illegal passage, a violation alarm will sound, and red notification lights will flash.

The SU4500 utilizes tandem motorized barriers, distributed processing and integrated optical sensors to control access. The optical sensors detect patrons, determine the direction of patron movement and (in conjunction with the facility access system) detect unauthorized users. In addition to detecting "piggybacking" or "tailgating" on allowed entries, the SU4500's sensors prevent barriers from closing on users. If the barriers do encounter an obstruction on either opening or closing, the SU4500's software detects the obstruction and takes corrective action, precisely controlling the motors to minimize impact.

While access control throughput will depend on the access control system and readers used, the SU4500 supports rapid throughput. It will "stack" valid scans and process patrons as fast as they can walk through the turnstile.

IP-based communication and configuration functionality is included in all SU4500 optical turnstiles, making it possible to adjust core turnstile settings using an included browser-based application called LaneConfig. Using a PC, tablet or smart phone, this application allows adjustment of configurable features – such as alarm sounds, motor settings, optical settings, detection settings, tailgating, alarm timer settings, etc. – over a TCP/IP network. If the turnstiles are not networked, adjustable features are configured by loading LaneConfig on a laptop and plugging directly into an Ethernet port in the turnstile.

Alvarado also offers a browser-based monitoring and scheduling application (optional) called GateKeeper. This application provides a virtual desktop of installed turnstiles, providing an attendant a convenient method to view and control day-to-day operational functions such as alarm notifications, implementing a one-time authorization signal, and changing turnstile operational modes.

GateKeeper also includes a scheduling function that allows a facility to automate changes in turnstile operational modes. This convenient functionality allows facilities to automatically implement desired turnstile operational changes at preset times such as at the beginning and end of shifts, lunch times, weekends, holidays, etc. GateKeeper provides a complete log of turnstile activity, for such items as activations, alarm conditions, and operational mode changes. Activities of attendants using GateKeeper are tracked as well.

More information about LaneConfig and GateKeeper is available in the Available Related Applications section of this document. Additional detailed information can also be obtained by contacting Alvarado technical support.

AVAILABLE CONFIGURATIONS

SU4500 / SU4500E

The SU4500 consists of a pair of end cabinets with moving barriers that create a single 28" wide passageway. The SU4500E is an extension center cabinet, with the same dimensions as an end cabinet, used to create additional turnstile passageway lanes with the addition of a single cabinet. For example, one SU4500 and one SU4500E would be used to create two lanes. Additional extension center cabinets are used to create additional lanes; e.g., one SU4500 and two SU4500Es create three lanes. An unlimited number of center cabinets can be added.



28" passage width

SU4500-A / SU4500E-A

The SU4500-A consists of a pair of end cabinets with moving barriers that create a single 36" wide passageway. The SU4500E-A is an extension center cabinet with wider barriers to allow an additional 36" passage lane to be created with the addition of a single cabinet as described in the section above. An unlimited number of center cabinets can be added.



Multi-lane configuration with 36" passage width on left and 28" passage width on right

USING TURNSTILE LANES WITH DIFFERENT PASSAGE WIDTHS

Center cabinets that have a 28" passage barrier on one side and 36" wide barrier on the other side are available.

AVAILABLE FINISHES

STAINLESS STEEL, POWDER COATED AND PLATED

External cabinet materials are fabricated from #304 stainless steel polished to a #4 satin finish. Powder coated and plated cabinets are available (see Options).

MATERIALS

CABINET

Cabinets are fabricated from #304 stainless steel.

CABINET LIDS

Cabinet lids are fabricated from Livingstone solid surface acrylic (color: Starry Night Black). Lids can also be provided in any available solid surface color. Stainless steel inlay framed by solid surface is available (see Options).



INTERNAL FRAME

A powder coated internal steel frame houses electronics, sensors, motors, and mechanical components.

MOVING BARRIERS

Clear moving barriers are fabricated from 0.5" (13 mm) thick acrylic with abrasion resistant coating. Barriers are 35" high and come in widths to create 28" or 36" passage openings. Moving barriers can be etched with a customer supplied design (see Options).

SIDE PANELS

Clear side panels are fabricated from 0.375" (9 mm) thick acrylic with abrasion resistant coating. Side panels can be etched with a customer supplied design and/or illuminated (see Options).

CONTROLS, OPERATIONAL MODES AND FUNCTIONALITY

CONTROL MECHANISMS

The precise movement of the SU4500's motorized barriers is accomplished through brushless DC motors working in conjunction with position encoders and motor controllers. A main turnstile controller runs the operational application and interfaces to the motor controllers and optics over an internal, high-speed serial bus. The turnstile controller also interfaces to Alvarado configuration and administrative applications, LaneConfig, GateKeeper and LEDConfig (if lighting option selected) via TCP/IP - see Available Related Applications.

PASSAGE MODES

The SU4500 offers the following user-configurable passage modes:

Controlled Passage Barriers are closed, securing the turnstile. Upon receipt of an authorization signal from an access control system, the barriers move away from the user to the open position, allowing a single passage in the authorized direction. The barriers return to the closed position after the user has passed through the turnstile or the time frame allowed for an entry to occur has expired. Controlled Passage can be implemented either in a single direction or bi-directionally.

Free Passage Authorization signal is not required for a user to pass through the turnstile in the free pass direction. Barriers are closed until a user enters the lane at which time the barriers automatically open in the direction of travel. While barriers are open, subsequent users can pass through the turnstile. If barriers begin to close and another user enters the lane in the free pass direction, the barriers will stop and reopen to facilitate rapid throughput. Barriers close when there are no users present and it is safe to do so. Free Passage can be implemented either in a single direction or bi-directionally.

No Passage (Direction Closed) No passage is allowed. The barriers are closed and remain closed. Valid electronic credentials are ignored and passage is not allowed. The barrier will still open in the "exit" direction if a fire alarm or life safety input is received. No Passage can be implemented either in a single direction or bi-directionally.



PASSAGE MODES (CONT.)

Visitor Allows visitors and groups without credentials access through the turnstile. When placed in visitor mode, the barriers open and remain open. Passages in either direction are monitored and an I/O output is provided for each passage.

OPERATING MODES

Normally Closed The barriers are closed securing the turnstile.

Barrier Disabled The barriers remain open, allowing the unit to function as a barrier-free optical turnstile.

USER STATUS DISPLAY

An illuminated status bar that is visible to users is flush mounted within the cabinet lid and is configured to function in the following manner:

Green An illuminated green bar indicates passage is allowed and/or valid credentials have been presented. A flashing green bar indicates the turnstile is in Free Passage mode on the side that is flashing.

Red An illuminated red bar indicates passage is prohibited. A flashing red bar indicates the turnstile has an alarm condition and/or invalid credentials have been presented.



OPEN / CLOSE STATUS LIGHTS

An opaque end piece is located on the cabinet just below the lid on each side of the turnstile, diffusing green and red signal lights. The lights function similar to toll booth lights, and perform in the following manner:

Green An illuminated green bar indicates the turnstile is open for use. The bar remains green when a valid card input is received.

Red An illuminated red bar indicates the turnstile is closed for use. The barrier will not open in the direction of travel unless the direction is "exit" and a fire alarm or life safety input is received.

Red Flashing A flashing red bar indicates the turnstile has an alarm condition. The duration of the alarm condition and flashing is user definable for select alarms through LaneConfig software.



FUNCTIONALITY - USER CUSTOMIZABLE FEATURES AND AVAILABLE TOOLS

Along with available passage and operating modes, the SU4500 has a number of additional user-customizable features. These features allow turnstiles to be “tuned” to the operational requirements of an application and allow users to associate individual audio sounds with operational states and alarm conditions. The SU4500 comes with tools to assist service personnel with setup, diagnostics and troubleshooting.

Customizable features and custom sounds are downloaded to turnstiles over a TCP/IP network using the included LaneConfig application. Users may create and install their own audio sounds in the form of .wav files.

Prior to shipping, turnstiles are configured with settings and default sounds that are appropriate for most facilities. A summary of configurable features and setup/diagnostic tools is listed below.

Operational Adjustments	Description
Barrier Breakaway	Controls barrier breakaway force if manually forced
Barrier Impact	Controls barrier operation if moving barriers encounter an object during operational cycle
Access Timeout	Valid credential presented but user does not pass through turnstile; controls time before barriers close and turnstile resets
Object	Controls object detection size
Tailgating	Controls tailgating sensitivity
Unauthorized Presence	Controls number of entry sensors a user can block before triggering alarm
Blocked Sensor	Controls time before alarm is generated if sensors are blocked

Operational Sounds / Alarms	Description	Configurable Sounds
Access Granted*	Good card	√
Access Denied*	Bad card	√
Unauthorized Presence*	User enters turnstile without presenting card	√
Tailgating/Unauthorized Passage*	Tailgating/unauthorized passage detected	√
Blocked Sensor	Sensors not cleared	√
Unsafe to Open/Close*	Barriers are not opening/closing due to unsafe condition	√
Barrier Breakaway	Barriers have been forced open	√
Barrier Impact	Barriers encounter an object when moving	√

Setup / Diagnostic Tools	Description	Configurable Sounds
Barrier Position (Home)	Barrier home position setting	N/A
Barrier Position (Open)	Barrier opening position setting	N/A
Startup	Appropriate startup engaged	√
Barrier Lingers	Barriers have stayed open past the allotted time to close	√
Debug	General debug application for troubleshooting	N/A
Optic Debug	Debug application for optics	N/A
Motor I/O Debug	Debug application for motor communication	N/A
Emergency Override Direction	Allows installer to set emergency override direction	N/A

*Configurable for both entry and exit direction



ALARM CONDITIONS

In the event of an alarm condition, the designated alarm sound is played (see chart on previous page) and both the status icon display and open/closed status lights will blink red. An I/O output is also provided for most alarm conditions - see Turnstile Interface to Access Control System section.

BARRIER BREAKAWAY

All SU4500 turnstiles utilize motor force and an electromechanical brake to provide adjustable resistance against a user pushing or pulling the barriers open. The force it takes to push or pull barriers open is an adjustable setting, up to the product maximum. Approximate maximum holding force measurements are available from Alvarado. When the set or maximum holding force is reached, the barriers “break away” and automatically reset to the home (closed) position.

BARRIER CYCLE TIME

This is an adjustable feature. Factory set, and recommended, opening speed is 1.0 seconds.

BARRIER IMPACT

In the event that the barriers encounter resistance while opening or closing, barriers will stop moving, an alarm will sound, and the user status display and open/closed status lights will blink red to indicate an alarm condition. The barriers will automatically reset once the obstruction is cleared. The barrier impact setting is adjustable.

EMERGENCY OVERRIDE / FIRE ALARM

Activation to open the barriers in conjunction with a fire alarm or other life safety system is achieved by supplying a sustained dry contact to the SU4500. During emergencies the SU4500 barriers will open in the exit direction and remain open. Status lights and alarm notifications will turn off.

POWER FAILURE

In the event of a loss of power to the unit, the barriers of the SU4500 can be freely moved in either direction. When pushed or pulled to the open position the barriers will remain open. As an available option, the barriers can automatically open in the exit direction on power loss. See ‘Automatic Opening of Barrier on Loss of Power’ in Options section.

CARD READERS

SPACE FOR INTERNAL INSTALLATION OF CARD READERS

Proximity readers can be mounted on either side of the turnstile underneath the cabinet lid. The internal space available is 2.125" H x 4.5" W x 8" D (54 mm x 114 mm x 203 mm). Alvarado can also provide other options for credential reader integration.



TURNSTILE INTERFACE TO ACCESS CONTROL SYSTEM

There are two types of interfaces to allow an access control system to operate with the SU4500:

Dry Contact

Single passage activation, and other functionality, is achieved by supplying an isolated, voltage-free, momentary dry contact at the appropriate location on the I/O control board. Various outputs are also available to provide information on turnstile operational status and activity. A description of available input and output signals is provided below.

Input Signal	Entry / Exit
Direction Closed	√
Good Card (Activation)	√
Bad Card	√
Passage - Free Pass Mode	√
Single Entry Override	√
Life Safety Input (Sustained dry contact)	√

Output Signal	Entry / Exit
Authorized Passage	√
Unauthorized Passage	√
Unauthorized Presence	√
Sensor Blocked	√
Lingering Barrier	√

TCP/IP

A TCP/IP interface is also available. This method allows a third party access system to control turnstile operation similar to the dry contact method, through the use of TCP/IP commands and responses. There is an additional charge for this interface method and implementation requires a programming effort on the part of the access system provider. Contact Alvarado for pre-evaluation of project requirements.

AVAILABLE RELATED APPLICATIONS

Software is included to customize the unit's LED lighting and effects, including custom colors and transitions. There are three additional applications that are available for the SU4500.

LANECONFIG

LaneConfig is a browser-based application that comes standard with all SU4500's. The application allows configurable features of the SU4500 and software updates to be installed over a network. Use of LaneConfig in a networked setting eliminates the need to physically plug into individual turnstiles to change turnstile configurations or update software. LaneConfig is accessible from a PC, tablet or smart phone that is networked to installed SU4500 turnstiles.

In installations where SU4500 turnstiles are not networked, LaneConfig is loaded on a laptop which is temporarily plugged into the Ethernet port of individual turnstiles when turnstile configurations are changed or software is updated.

GATEKEEPER

GateKeeper is an optional browser-based application that allows all Alvarado optical turnstiles installed at a site to be monitored and controlled from a single PC. GateKeeper allows control of virtually all day-to-day operating functions, including designating a turnstile as entry or exit, opening or closing a turnstile, and allowing single passage overrides for guests or personnel that have forgotten their access card. The application also includes various other



GATEKEEPER (CONT.)

functions. These include an emergency “open all turnstiles” capability that is in addition to the emergency override/fire alarm capabilities described earlier in this document. The application has tiered login levels with three levels of security (User, Supervisor and Administrator). The higher permission levels enable various additional features and settings.

GateKeeper has an intuitive web interface that gives desk attendants a current “status” of all installed turnstiles. In addition, when alarm conditions occur, the application provides both visual and audio notification of what happened. All actions (such as passage overrides), and turnstile alarms, are logged. Logs may be printed or saved for recordkeeping or diagnostic purposes.

GateKeeper also includes a built in Event Scheduler. This extremely useful tool allows day-to-day operational changes that are often implemented at sites to be scheduled and automatically implemented without the need for a guard or attendant to “remember” to change settings. Event Scheduler allows operation templates to be saved and then automatically implemented at user-defined times. Examples include changing the entry status of turnstiles (entry, exit, bi-directional control or free passage) at set times of the day. Similarly, a facility may want barriers activated or disabled at select times and/or only specific lanes operational on weekends and holidays. This flexibility allows turnstiles to be used more efficiently, can decrease the number of turnstiles that may be needed and allows Alvarado’s optical turnstiles to seamlessly integrate into a customer’s operational requirements.

A single license of GateKeeper allows users to control all turnstiles installed at a single licensed site.

LEDCONFIG

LEDConfig is a browser-based application that operates in conjunction with the Dynamic Side Panel Illumination Option. The Dynamic Side Panel Illumination Option adds LED’s that illuminate the SU4500 side panels and networks them on bus along with the user status display lights, open /closed status lights.

The LEDConfig application allows a user to modify all lights of the SU4500 to illuminate in any RGB color. The application also supports multiple transition effects as light colors automatically change.

Examples of what you can do with the Dynamic Illumination Option and LEDConfig application:

Side Panels

- Configure in a single color
- Configure so that while idle the panels transition between up to three colors (matching company or décor colors). For instance, panels on the unsecured side can be illuminated yellow while the panels on the secured side transition between blue and fuchsia, or vice versa
- Select from six transition animations, such as “wipe in”, “wipeout” , “blink” etc.
- Configure any or all panels to illuminate (in any RGB color) on receipt of “good” credential signal
- Configure any or all panels to illuminate (in any RGB color) on receipt of “bad” credential signal
- Configure any or all panels to illuminate (in any RGB color) when an alarm condition occurs

User Display and Open / Close Status Lights

The lights can be programmed to operate in standard red/green mode as described on page 5. Additionally, however, the lights can be programmed to illuminate in any color and to utilize animation effects between color transitions.



OPTIONS

ALTERNATE LID COLORS AND MATERIALS

Lids can be provided in any available solid surface color. Lids with a laser cut stainless steel inlay within a solid surface frame can be provided. Select alternate materials are also available.

ALTERNATE POWER SUPPLY

A 220-240 VAC, 50 Hz power supply and EU wiring scheme.

AUTOMATIC BARRIER OPENING ON LOSS OF POWER

An enclosure houses the turnstile UL listed power supply and power buffer. On loss of power, the power buffer retains power to automatically open the barriers in the exit direction.

BARRIER / SIDE PANEL ETCHING

Customer's choice of logo/artwork may be etched on the moving barriers and/or side panels. Contact Alvarado for space limitations.

BARRIER WIDTHS

Moving barrier widths may be customized to meet unique installation requirements.



Barrier Etching

PLATFORM

A platform for either single turnstile or multi-turnstile configurations is available. The passageway area of the platform is powder coated with a highly-textured black coating. The platform includes enclosed cable runs and eliminates the need for trenching or stubbing up conduit from floor.

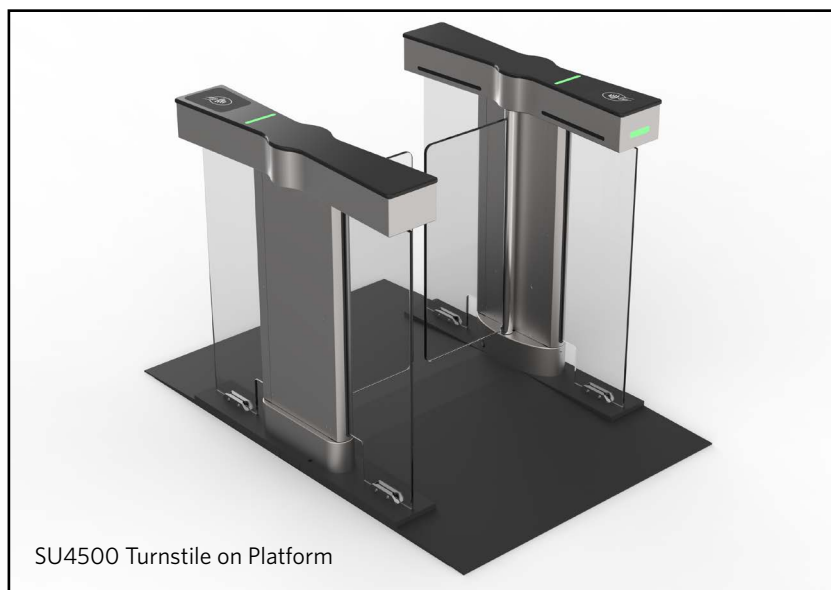

OPTIONS (CONT.)

CARD READERS / PHYSICAL ACCESS DEVICE INTEGRATION

To accommodate larger readers and similar user interface devices, please contact Alvarado.

CLIMB OVER DETECTION

Load cells are installed underneath the lid to detect an unauthorized user attempting to climb on the lid to gain entry.

CUSTOM CABINET FINISHES

External cabinet materials may be powder coated in a variety of colors. Cabinet materials can also be plated in a variety of finishes.

ELEVATOR DESTINATION DISPATCH

The SU4500 can integrate with virtually any Elevator Destination Dispatch solution to direct users to the correct elevator when presenting their authorized credentials. Most dispatch displays can be integrated directly into the turnstile.

LONGER INTERCONNECT BETWEEN CABINET CABLES

Longer interconnect cables are available to accommodate installations where standard conduit runs are not available. The standard interconnect cable length is 8' (244 cm). Cables are also available in 13' (396 cm), 20' (610 cm) or 40' (1220 cm) lengths.

SIDE PANEL ILLUMINATION (DYNAMIC)

The Dynamic Side Panel Illumination allows a user to illuminate the SU4500 side panels in various RGB colors and create various transition lighting effects. Please see page 9 for a fuller explanation of this option and the associated user application, LEDConfig.

TCP/IP

See the description under Turnstile Interface to Access Control System.

MONITORING AND OPERATIONAL MODE SCHEDULING SOFTWARE

GateKeeper web-based communication and control software communicates with SU4500 turnstiles over a wired TCP/IP network. For more information, see the description provided earlier in this document or contact Alvarado.

TURNSTILE KEY CONTROLS

There are two 3-position key switches installed on the turnstile to control passage modes for both directions of travel. Turning the key to one of three positions overrides current settings placing the turnstile in Controlled Passage mode, Free Passage mode or No Passage mode depending on orientation of the key.



CONDUIT REQUIREMENTS

PRIMARY POWER CONDUIT

.75" (19 mm) conduit for low voltage 24V primary power must be run to each main controller cabinet.

LOW-VOLTAGE AND COMMUNICATION CONDUIT

1.5" (38 mm) conduit must be run to allow passage of the interconnect cable between cabinet sets. 8' (244 cm) interconnect cables are included. 13' (396 cm), 20' (610 cm) and 40' (1220 cm) interconnect cables are available options.

ACCESS CONTROL SYSTEM AND READER CONDUIT

The SU4500 has space for the acceptance of a .75" (19 mm) conduit for access control and reader cabling. Alvarado does not provide cables for access control systems.

TCP/IP CONDUIT

Use of TCP/IP communication with LaneConfig or GateKeeper requires the running of an Ethernet cable to each main controller cabinet.

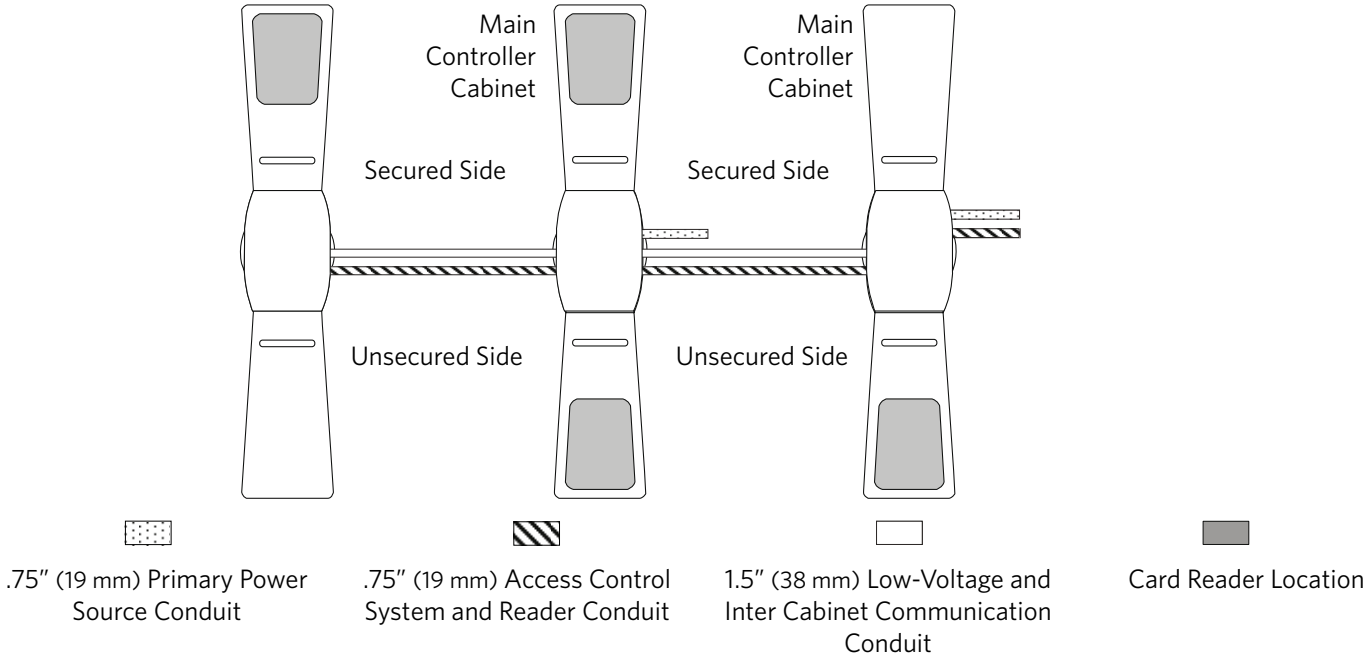

SHIPPING AND SITE PREPARATION

SHIPPING

SU4500 cabinets are shipped assembled for easy installation. Each cabinet includes mounting hardware (anchors, bolts, washers, etc.) to mount the unit to a standard, level concrete floor.

SITE PREPARATION

Turnstiles must be installed on a firm foundation in a manner that allows the required power and access control cabling to be pulled into the turnstile cabinet. The slab platform should be a minimum of 4" (102 mm) deep, level concrete. Installation should be performed by a skilled installer following Alvarado's instructions. Detailed drawings and installation manuals are available online or by contacting information@alvaradomfg.com

TECHNICAL DIMENSIONS

Dimensions are shown in inches (mm). All measurements are approximate.

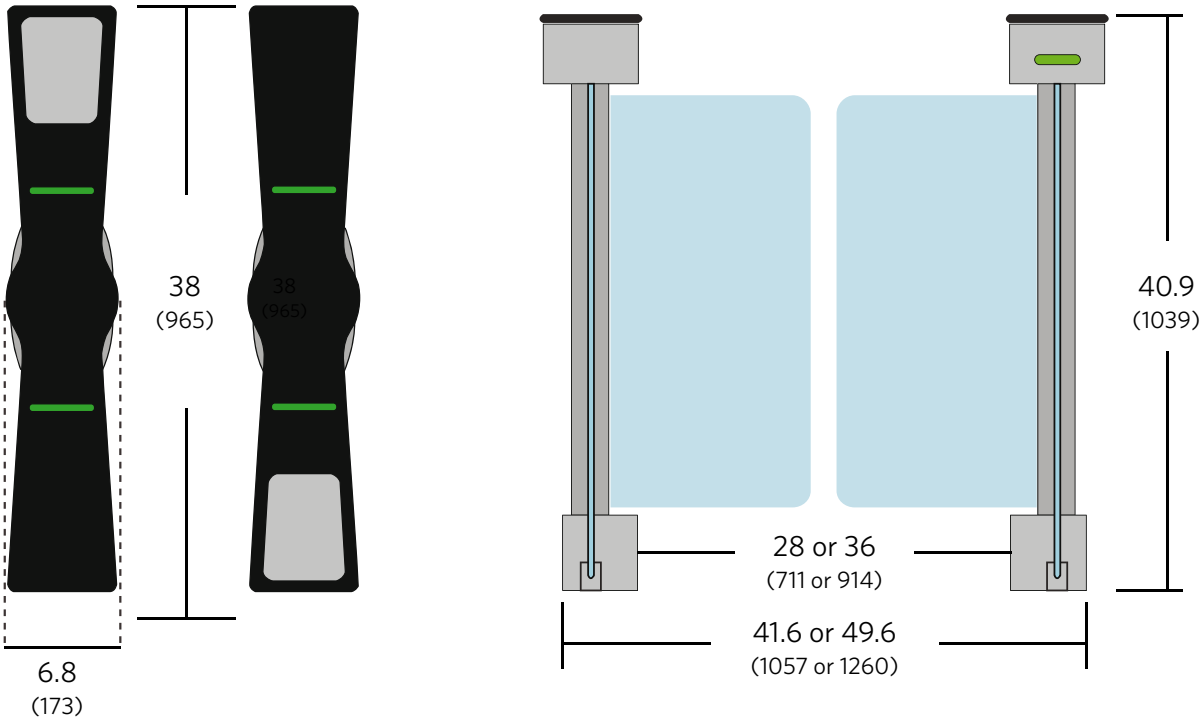

Approximate Throughput Rates	
Card Reader Type*	Users per minute
Proximity	40

*Access control system response is assumed to be instantaneous

Electrical	Description
UL Rated Power Supply	110-120 VAC, 60 Hz or 220-240 VAC, 50 Hz to 24VDC
Power Supply Location	The power supply comes pre-wired in an enclosure for installation in a wiring closet or similar suitable location. The enclosure comes with conduit entry / exit ports for primary power input and 24VDC out to the turnstile. Each turnstile requires one power supply for operation. A single enclosure can house up to three power supplies. Follow Alvarado recommendations for low voltage wire gauge runs.
Operational Voltage	24VDC is run to the turnstile and is used for motors and motor controllers; 24VDC is stepped down internally for 12VDC and 5VDC operations.
Power Consumption	Peak: 65W / Operating: 40W / Idle: 20W
On/Off Key Switch	An on/off key switch is located on each main cabinet.
Fuse Protection	A 2.5 amp fuse (slo-blo) is installed in each main cabinet.
Surge Protection	Alvarado suggests use of surge protection equipment in connection with the installation to protect electronics
Weights and Environmental	
Product Weight	200 lbs. 91 kg Weight for a standard 28" lane (two cabinets)
Shipping Weight	275 lbs. 125 kg Includes weight of shipping crate(s)
Operating Temperature	50° to 90° F 10 to 32° C
Storage Temperature	32° to 104° F 0 to 40° C
Relative Humidity	15-85% (non-condensing) --

WARRANTY

For a period of 18 months from the date of purchase, Alvarado will replace or repair, at Alvarado’s option, any products or parts which are defective in materials or workmanship, provided recommended installation and maintenance procedures are followed. This warranty is void if damage is due to improper installation, maintenance or use. This warranty is limited to parts only, and does not cover labor or shipping charges incurred in connection with the removal or replacement of warranted products or parts.

This warranty is expressly made in lieu of any and all other warranties, expressed or implied, including, but not limited to implied warranties of merchantability and fitness for a particular purpose. Alvarado shall not be liable for any loss or damage, directly or indirectly, arising from the use of purchased products. In no event shall Alvarado be liable to buyer for consequential damages, special damages, incidental damages, loss of use, business interruption, loss of profits, or damages of any kind arising out of the use or inability to use a purchased product. In no event shall Alvarado be liable for damages which exceed the purchase price of a covered product.

