

Quick Queue Portable Retractable Belt Stanchion - Installation Instructions



Notice: Installers and/or Store Personnel must provide this document to the manager or person responsible for the maintenance and use of the product. Read the Installation Instructions completely before installation of the product. If there are any questions, call Alvarado at (909) 591-8431 or toll free at (800) 423-4143, Monday through Friday, 6:00 AM to 4:30 PM PST.

Materials Enclosed:

- | | |
|-------------------------|--------------------------|
| 1. Post (Qty: 2) | 4. Steel Washer (Qty: 2) |
| 2. Base Cover (Qty: 2) | 5. Rubber Ring (Qty: 2) |
| 3. Base Weight (Qty: 2) | 6. Hex Bolt (Qty: 2) |

Tools Required: Adjustable Wrench (16mm)

Follow the Instructions to Assemble a Quick Queue Stanchion:

1. Place the Post upside-down on a padded surface to prevent the top of the Post from being scratched.
2. Assemble the unit by fully inserting the Hex Bolt through the Steel Washer, Base Weight, Base Cover, Rubber Ring and Post as shown in FIGURE 1.
3. While properly aligned, smoothly hand-tighten the Hex Bolt.
4. Use a Wrench to securely tighten the Hex Bolt to the Post while holding onto the Post. **Do NOT rotate the Post to tighten the bolt**, as this will break the Rubber Ring or scratch the Base Cover.

Follow the Instructions to Operate the Belt:

1. **Extend & Lock:** EXTEND the belt from the Post and slide the belt end onto the desired receiver. To LOCK, turn the dial at the bottom of the belt end to the "Locked Position." **Recommendation: Lock to minimize unintentional or unauthorized release of the belt.**
2. **Unlock & Retract:** To UNLOCK, turn the dial at the bottom of the belt end to the "Unlocked Position." To RETRACT, slide the belt end upwards and walk the belt end completely back to the Post. See Figure 2 for pictorial illustration of locked and unlocked position.

Maintenance: Follow the instructions for the corresponding finish

Chrome:

Use a general all-purpose cleaner with a soft cloth.

Stainless Steel:

Use a Stainless Steel polish or cleaner. If a heavy scratch or mark is apparent, use a metal blend or finish pad for Satin Finishes.

Powder Coat:

Use a soft damp cloth. Any deep scratches or chips should be touched up to prevent rust.

(If rust is untreated, rust will spread under the surface of the material.)

Replace any sharp, bent, or broken pieces **IMMEDIATELY**. Tighten any loose pieces.

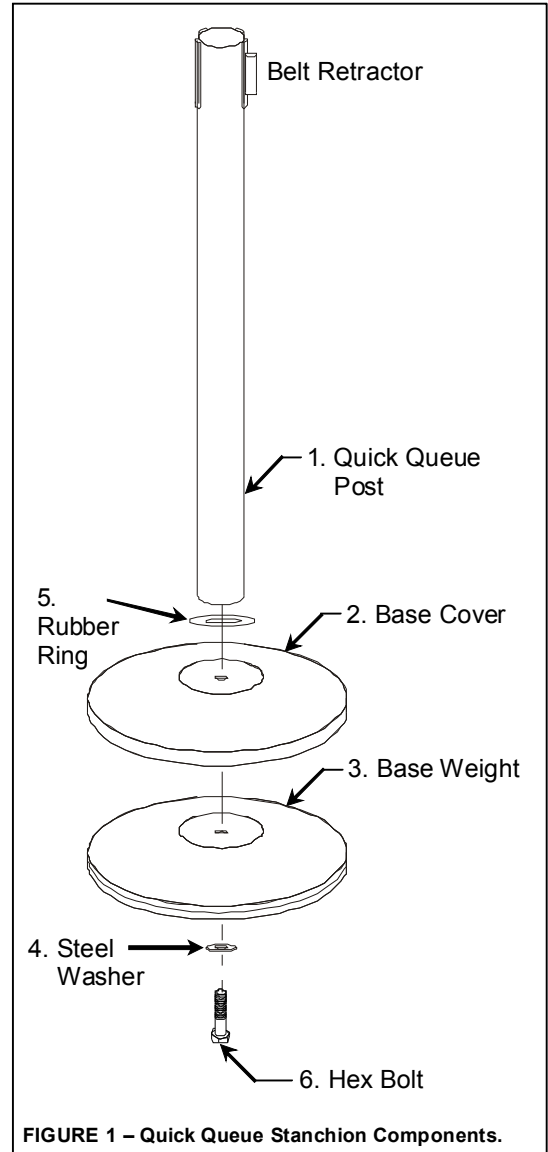

FIGURE 1 – Quick Queue Stanchion Components.

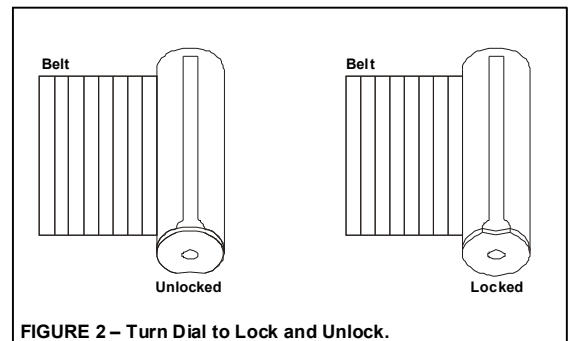

FIGURE 2 – Turn Dial to Lock and Unlock.

Warranty: Alvarado Manufacturing Company warrants the equipment being sold against defects in material and workmanship, for the period of one (1) year from the date of purchase, providing recommended installation and maintenance procedures are followed. This warranty is void if damage was due to improper installation, maintenance, or use. The manufacturer will not be responsible for any shipping or labor charges incurred in the removal or replacement of defective parts.