

SSB

Floor Bumper

The SSB removable floor bumper protects walls, refrigeration units and other fixtures from impact damage caused by shopping carts, floor cleaners and stocking equipment. The product provides a clean, understated look and superior impact protection.

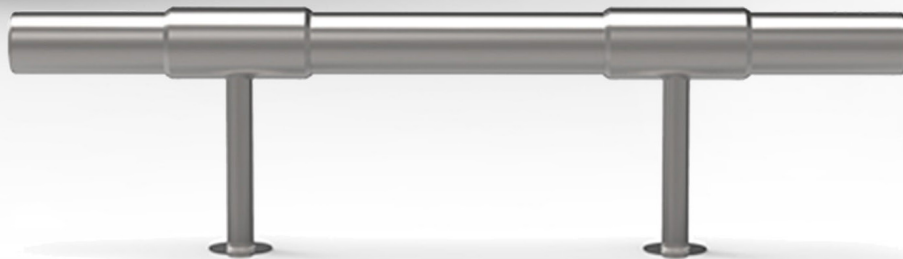

Fixture Protection



Grocery Stores



Store Backroom



Club Stores



Retail Stores

SSB Floor Bumper

Alvarado's SSB removable floor bumper protects walls, refrigeration units and other fixtures from impact damage. The SSB is often used in grocery stores, retail stores and store backroom areas.

Product Features

- Removable for easy floor cleaning
- Individual sections connect to create seamless runs



Material and Finish

- 16-gauge, stainless steel tubing
- #4 satin finish

Available Lengths



The SSB is available in individual sections from 1' to 12'. Additional sections and corners can be added to create longer runs along walls, cases, and windows.

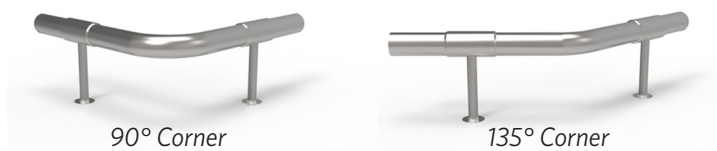

Compact Design



The SSB can be installed close to walls and fixtures, minimizing trip hazards.

Dimensions

Measurements in inches (mm)

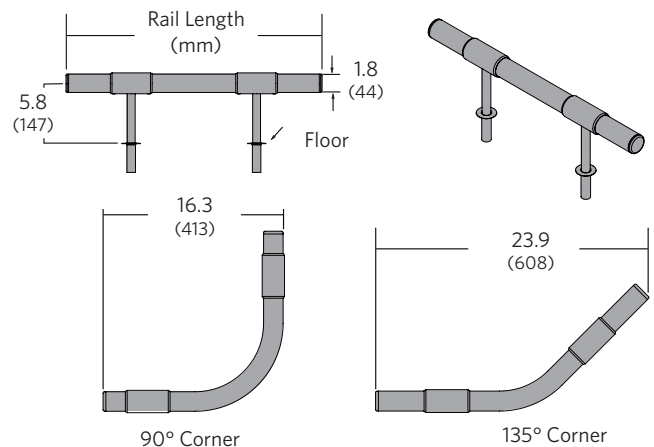

*Available individual rail lengths in feet (mm)

1' (305)	2' (610)	3' (914)	4' (1219)	5' (1524)	6' (1829)
7' (2134)	8' (2438)	9' (2743)	10' (3048)	11' (3353)	12' (3658)

Complementary Products



SS and XT removable corner guards are a highly effective method of preventing damage to expensive store fixtures and equipment.