

UltraQ Pedestal Guide
PUD4599R2-0 Version 1.0

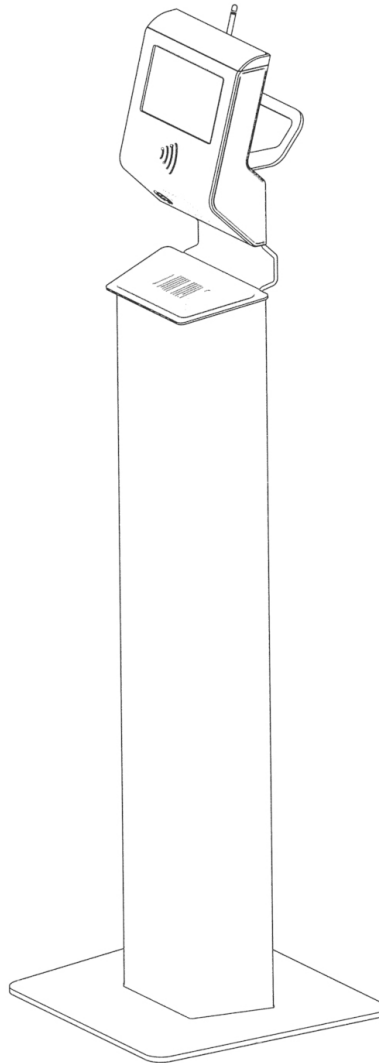

Alvarado Manufacturing Company, Inc.
12660 Colony Street, Chino, CA 91710
Telephone: (909) 591-8431
Fax: (909) 628-1403
support@alvaradomfg.com
www.alvaradomfg.com



Contents

Preface.....	3
Document Overview.....	3
Support.....	3
Assembling the Pedestal.....	4
Items Required.....	4
Procedure.....	5
Basic Functionality Test.....	8
Battery Operations.....	9
Items Required.....	9
Checking Battery Charge Level.....	9
Charging the Battery.....	10
Removing/Installing the Battery.....	11
Using the Removable Dolly.....	13
Attaching the Dolly.....	13
Removing the Dolly.....	14
Revision History.....	15



Preface

Document Overview

This document describes how to set up a battery-powered portable Alvarado UltraQ pedestal for first-time use.

Support

Contact Alvarado's Entertainment Support department for any questions or comments you have about this guide or the processes it describes.

Phone: 909-591-8431

Email: helpdesk@alvaradomfg.com



Assembling the Pedestal

The pedestals are shipped in three pieces: the pedestal base, the pedestal post, and the UltraQ head. Follow the directions below to assemble the pedestal.

Items Required

- Size 5/32" hex key
- Size 7/16" open wrench or socket wrench
- Mounting hardware (included in UltraQ head box)
 - 4x hex screws (91-1338)
 - 4x split lock washer (91-4203)
 - 4x nuts (11-1648)
 - 4x flat washers (91-3201)



Procedure

1. Remove a baseplate and a pedestal post from their boxes.
2. Line up the screws on the baseplate with the holes in the pedestal post and lower the post onto the baseplate.
3. Use the 7/16" wrench with the nuts and flat washers to secure the pedestal post to the baseplate.

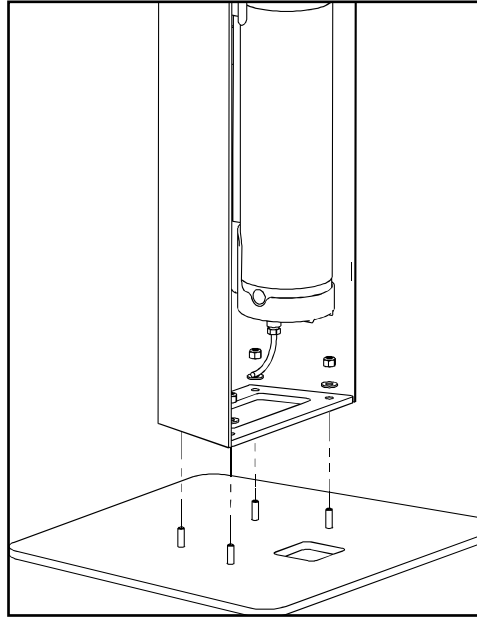

4. Remove the UltraQ head and mounting hardware from the box.
5. Use the 5/32" hex key with the hex screws and split lock washers to secure the UltraQ head to the pedestal post.

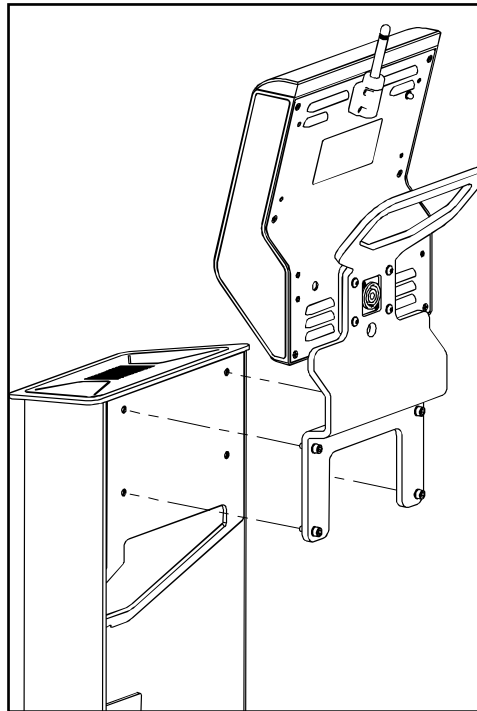



6. Connect the Neutrik connector to the back of the UltraQ head.

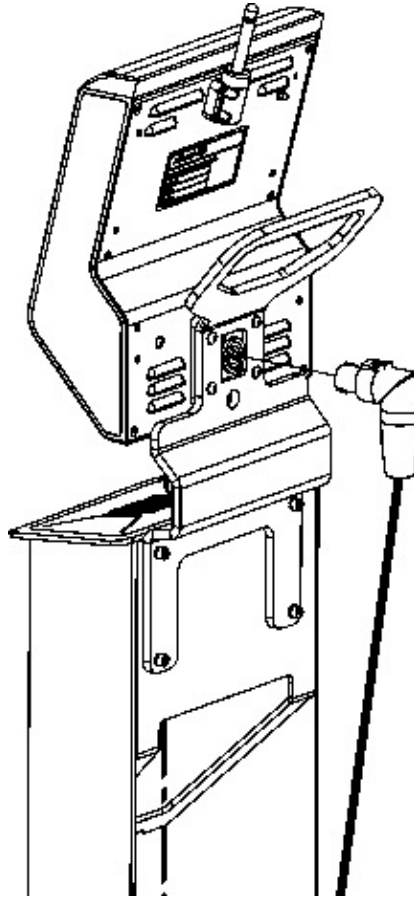



7. Verify the power cable plugging into the bottom of the battery is securely connected.
8. Verify the **battery power switch** (located under the battery) is set to **on**.
9. Remove the key from the battery.
10. Ensure the battery is securely latched in the bracket.

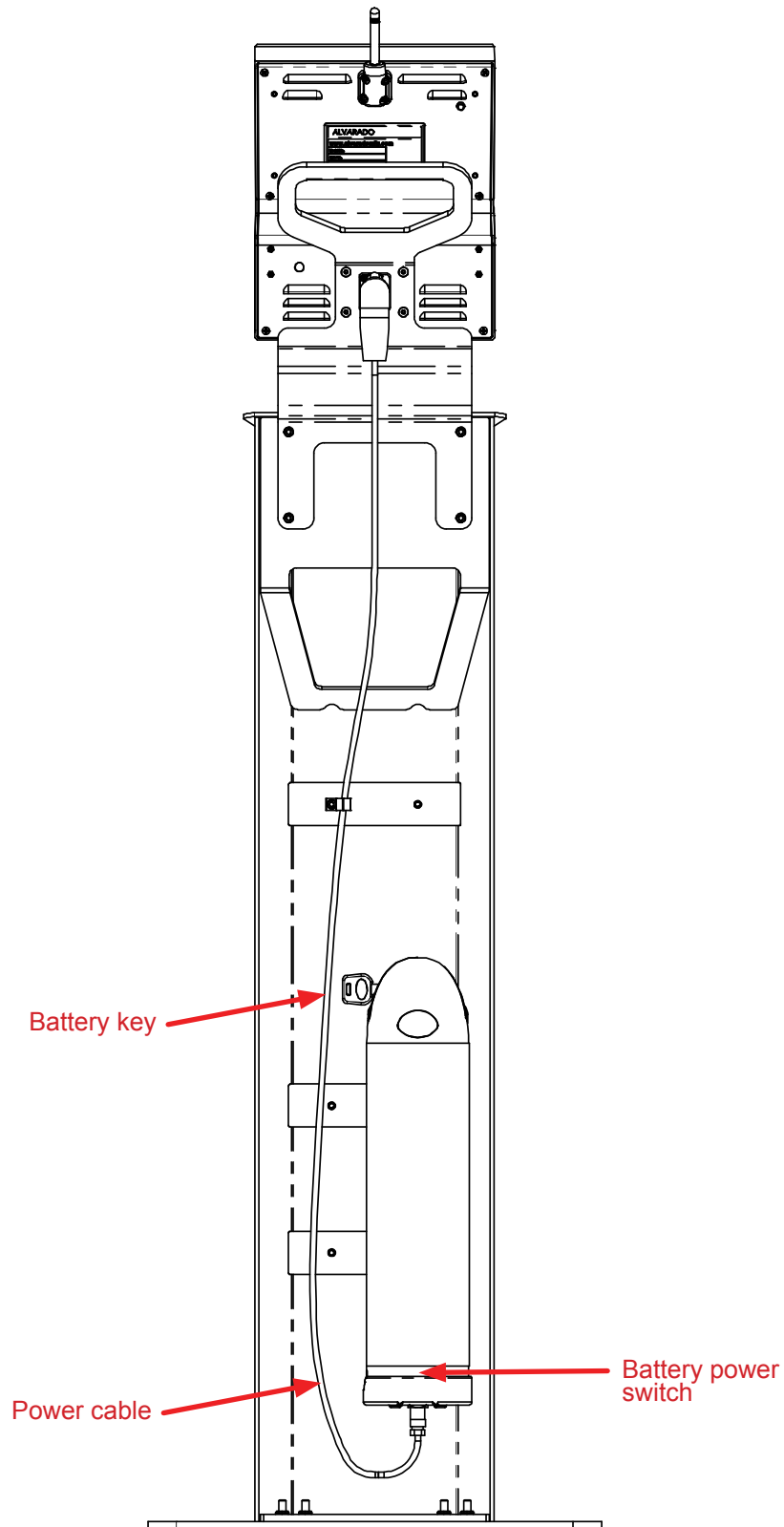



Basic Functionality Test

After setting up the pedestal, press the **recessed power button** and verify the UltraQ powers on. If it does not power on, check the items listed below.

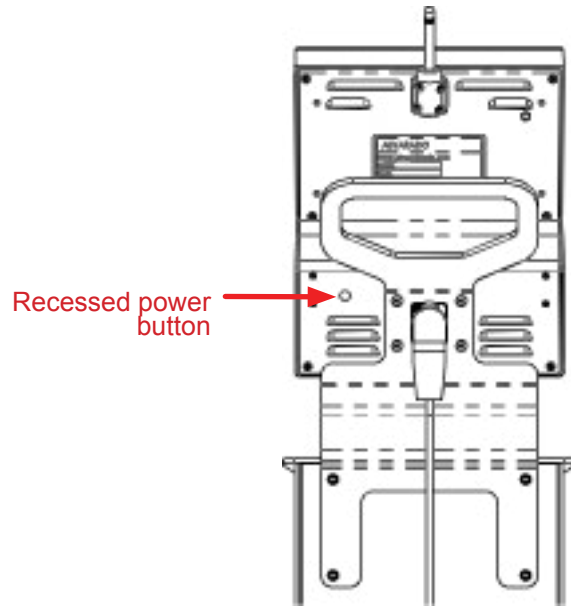

- Verify the power cable is plugged into the back of the UltraQ head.
- Verify the battery cable is plugged into the bottom of the battery.
- Verify the battery is switched on.
- Press the power button on the battery to verify it is charged (see next section). Charge the battery if required.



Battery Operations

Items Required

- Battery key
- Replacement battery

Checking Battery Charge Level

Press the gray charge level display button on the battery to display the current charge level of the battery. A new, fully charged battery should be able to allow continuous pedestal operation for up to 18 hours. The maximum time the battery can power the pedestal will decrease as the battery ages.





Charging the Battery

The charger is in the power supply box. It should take about three hours to fully charge a new battery.

1. Plug the charger into power.
2. Connect the socket to the battery's charging port.

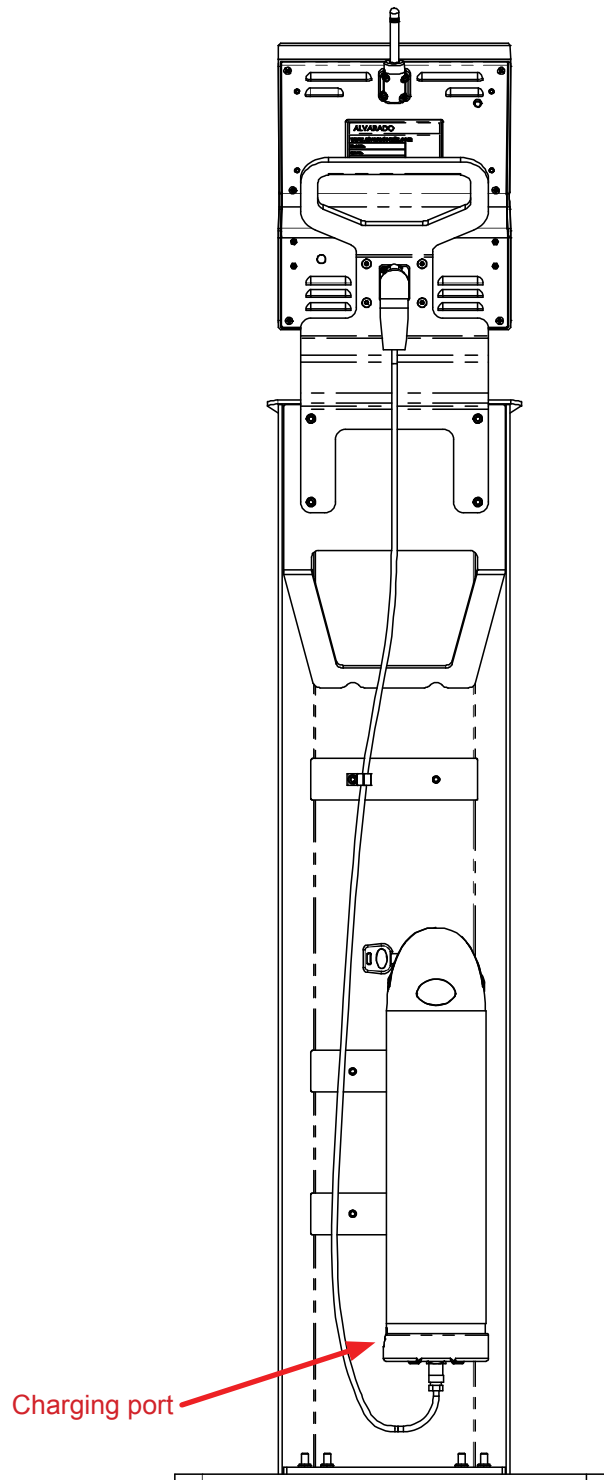

(Shown with the printer box open from the right-hand side.)



Removing/Installing the Battery

To remove the battery:

1. Press the button on the connector to separate it. Each half of the connector is keyed, so it will only reattach one way when you replace the battery.
2. Use the battery key to detach the battery from the bracket. You don't need to use the key when reattaching the battery.
3. Tilt the battery away from the pedestal and lift the battery out of the bracket. Care should be taken when pulling the battery cable through the bottom hole of the holding bracket to prevent scraping and/or catching.

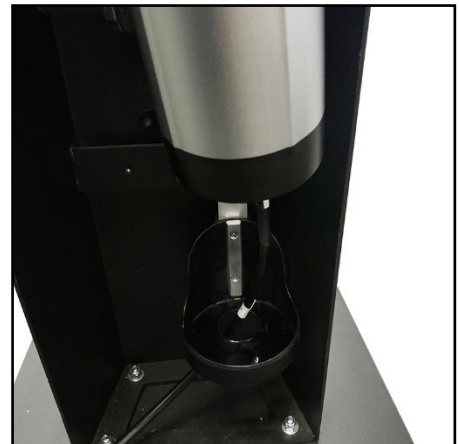



To replace the battery:

1. Place the bottom of the battery in the frame. The cutout section of the top of the battery should be facing the pedestal.
2. Tilt the top of the battery toward the pedestal until the locking latch clicks.
3. Reconnect the quick-connect cable ends



Using the Removable Dolly

Attaching the Dolly

1. Lean the UltraQ pedestal forward so the back edge of the baseplate is off the ground.
2. Slide the dolly's guide tab into the hole into the dolly hole on the backplate.
3. Tilt the dolly downward and slide it forward until the catch is flush with the backplate.

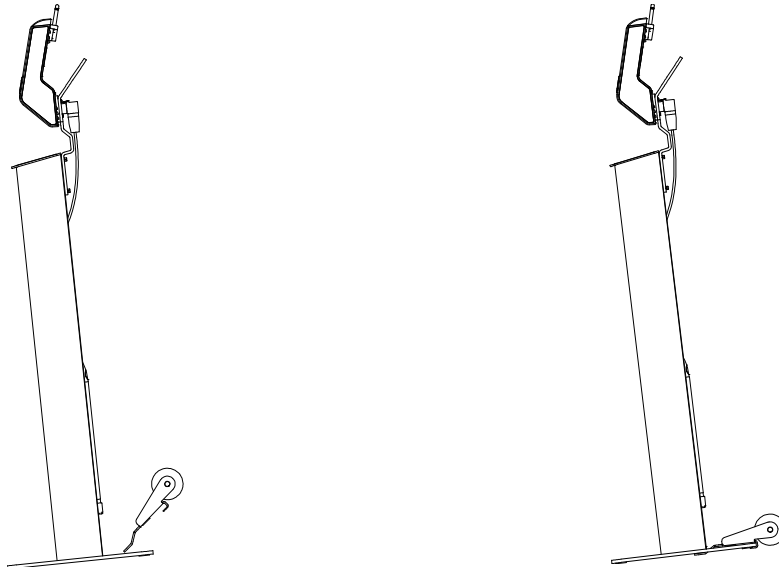

4. Use the handle to lean the UltraQ pedestal onto the dolly's wheels and push/pull it to the desired location.

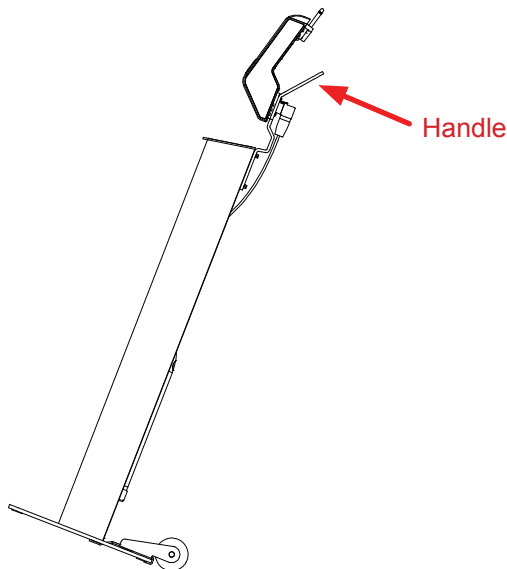



Removing the Dolly

1. Lean the UltraQ pedestal forward so the dolly's wheels are off the ground.
2. Pull the dolly away until it is no longer snug against the baseplate.
3. Tilt the dolly up and remove it.



Revision History

Revision	Date	Author	Revision History/Description
1.0	1/12/2022	D Bohannon	Original Document



Alvarado Manufacturing Company, Inc.
12660 Colony Street, Chino, CA 91710
Telephone: (909) 591-8431
Fax: (909) 628-1403
support@alvaradomfg.com
www.alvaradomfg.com