

8 7 6 5 4 3 2 1

D
C
B
A

D
C
B
A

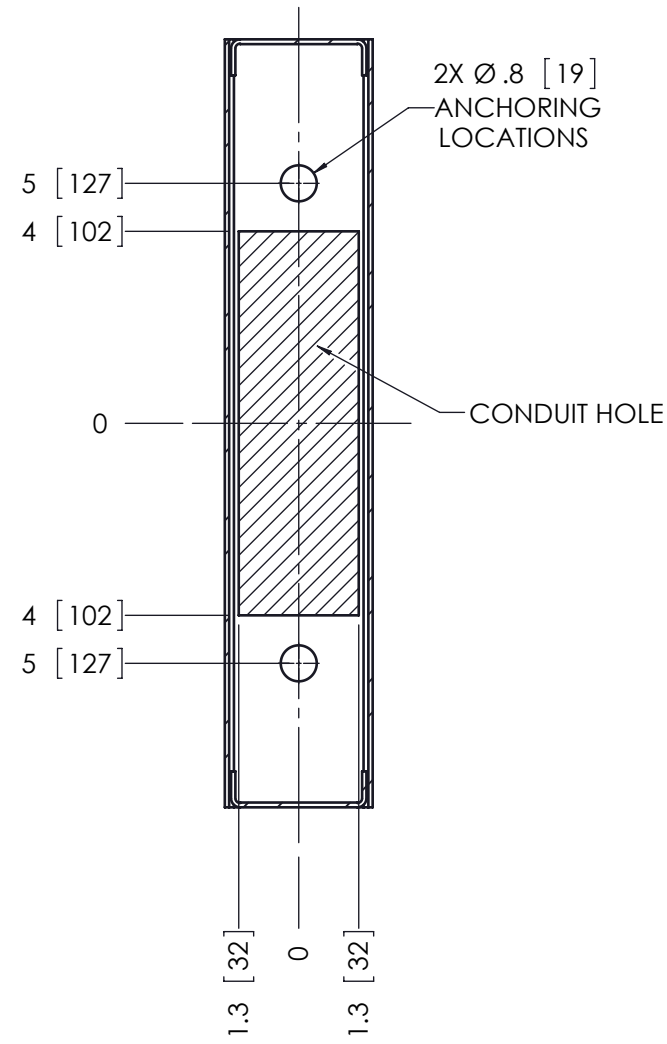
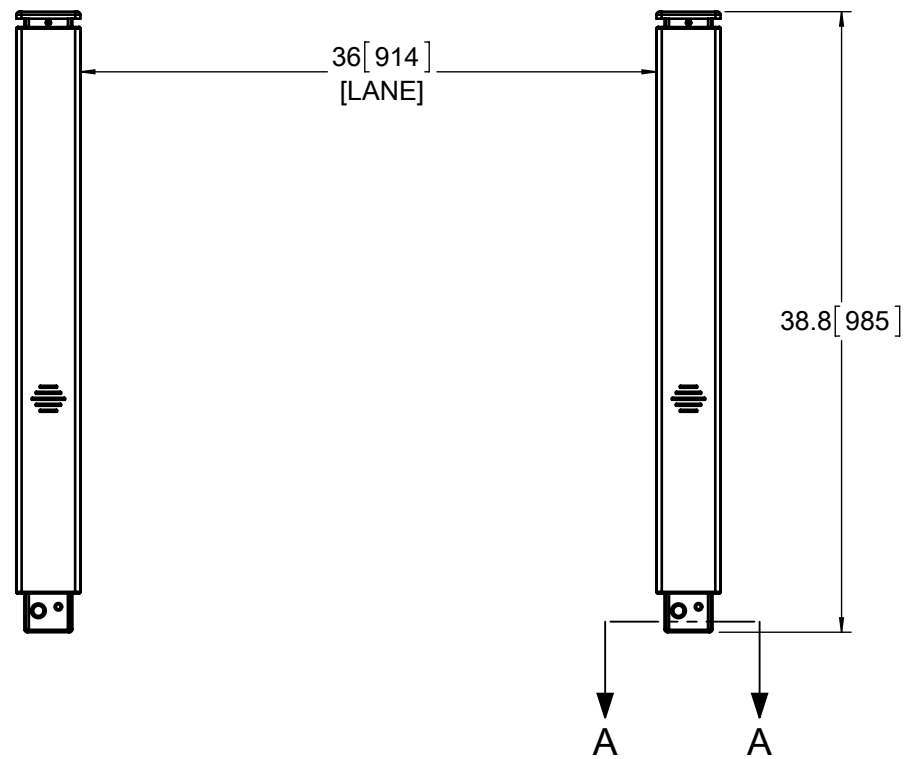
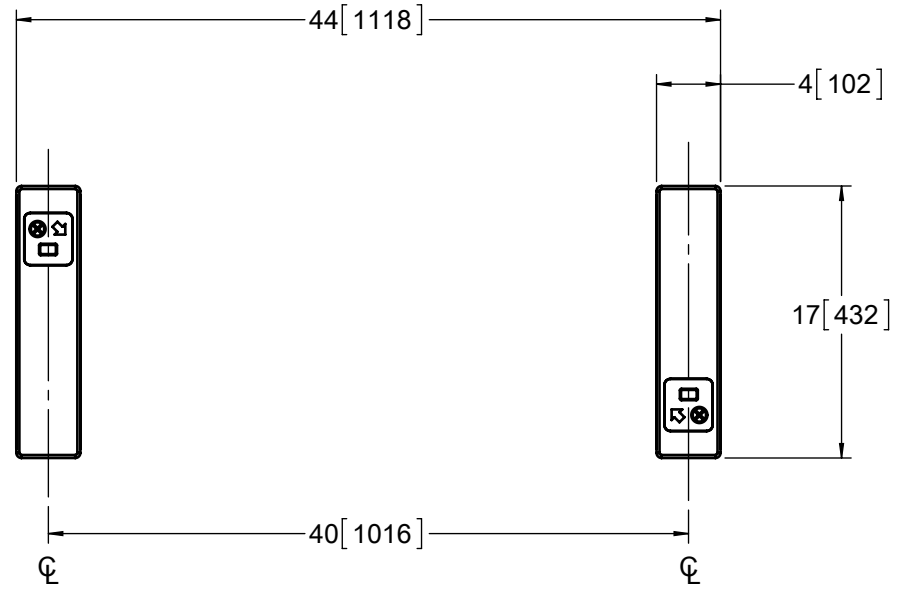

SU500 / SU2000
SECTION A-A
(DO NOT SCALE)

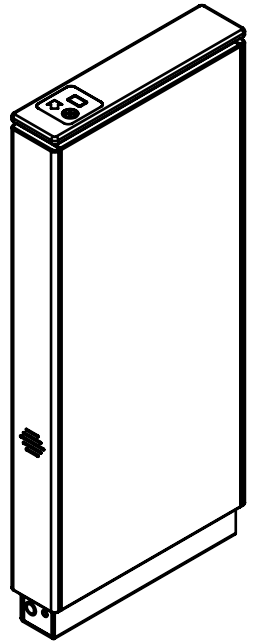
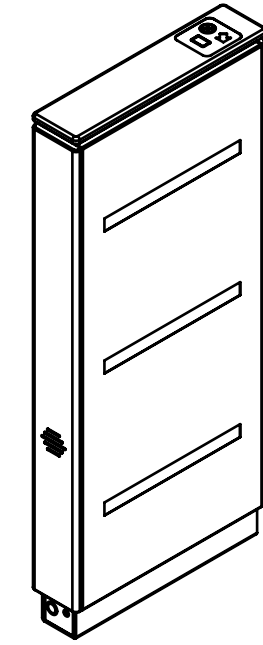

NOTES:

1. ALL DIMENSIONS ARE APPROXIMATE AND IN INCHES [mm].
2. EACH CABINET SHOULD BE MINIMUM 6" FROM WALL TO ALLOW FOR SERVICING.
3. ALVARADO RECOMMENDS 28" WIDTH LANES BE USED FOR GENERAL PURPOSE ENTRY/EXIT CONTROL. ALVARADO RECOMMENDS 36" WIDTH LANES BE RESERVED FOR USE BY PATRONS WITH SPECIAL REQUIREMENTS.

THIRD ANGLE PROJECTION

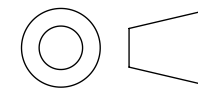

PROPRIETARY AND CONFIDENTIAL

THE INFORMATION CONTAINED IN THIS DRAWING IS THE SOLE PROPERTY OF ALVARADO MANUFACTURING INC. ANY REPRODUCTION IN PART OR AS A WHOLE WITHOUT THE WRITTEN PERMISSION OF ALVARADO MANUFACTURING INC. IS PROHIBITED.

DO NOT SCALE DRAWING



Alvarado Mfg. Co. Inc.
12660 Colony Street, Chino, CA 91710
909.591.8431 - 909.628.1403 (Fax)
www.alvaradomfg.com

TITLE:

SU2000, 1 LANE, 36"

	NAME	DATE	SIZE	DWG. NO.	REV
DRAWN	RGM	2/2/2015	B	PEF-468	B
CHECKED					
ENGR	RPL	2/2/2015	SCALE: 1:12		SHEET 1 OF 1

8 7 6 5 4 3 2 1