

ALVARADO

Supervisor 3000-SM **Barrier Arm Optical Turnstile for Indoor Installation**



Technical Specifications

Dimensions	<u>Cabinet Length:</u>	48" (1219mm)
	<u>Cabinet Height:</u>	38.5" (978 mm)
	<u>Cabinet Width:</u>	9.625" (245 mm)
	<u>Clear Passage Width:</u>	30" (762 mm) or 36" (915 mm)
	<u>Barrier Arm Diameter:</u>	1.75" (45 mm)
	<u>Barrier Arm Length:</u>	14" (356 mm) or 17.5" (445 mm)
Drive	Motorized	
Materials	<u>Base:</u>	Formed and welded carbon steel. Powder coated RAL 9017, <i>Solar Black (matte)</i> .
	<u>Internal Frame:</u>	Welded steel. The frames provide the mounting for the stepper motors and drivers, barrier arm mechanisms, controller boards, and optical sensor components and are configurable for use as center cabinet frames in multi turnstile installations.
	<u>End Panels:</u>	Formed and welded 304 stainless steel. All exterior welds are ground smooth and polished. Available in #4 satin or powder coated finish.
	<u>Side Panels:</u>	Formed and welded 304 stainless steel. All exterior welds are ground smooth and polished. Available in #4 satin or powder coated finish.
	<u>Lid:</u>	Samsung Staron® acrylic resin, <i>Sanded Onyx</i> .
	<u>Arm:</u>	Aluminum tubing. Arm is sealed at one end with an aluminum cap, welded and ground smooth. Available in #4 satin or anodized finish.
	<u>Arm Alcove:</u>	Vacuum formed ABS Plastic. <i>Black</i> .
Function	The SU3000-SM offers the following user configurable operational modes of bi-directional (card in / card out) electronically controlled access:	
	<u>Normally Closed:</u>	Barrier arms remain raised, securing the turnstile. Upon receipt of an authorization signal from the access control system the arms will drop and allow a single passage in the authorized direction. The barrier arms will reset and return to the raised position after the user has passed through the turnstile or the time frame allowed for an entry to occur has expired.
	<u>Normally Open:</u>	Barrier arms remain down, providing a barrier free passageway. The barrier arms will not raise and secure the turnstile unless tailgating or an unauthorized passage is attempted.
	<u>Barrier Disabled:</u>	Barrier arms remain down at all times allowing the SU3000-SM to function as a barrier free optical turnstile.

Control Mechanism	<p>The SU3000-SM utilizes tandem motorized barrier arms to control access. Movement of each arm is accomplished with a drive chain connected directly to a DC stepper motor drive unit working in conjunction with a bi-directional encoder. A controller board provides accurate positioning and movement of the arms.</p> <p>Optical safety sensors prevent the arms from closing on an obstruction. Should the movement of the arms be obstructed, the controller board detects the encumbrance and reverses the arms away from the obstruction to either the fully open or fully closed position.</p>
Method of Operation	<p>Upon receipt of a signal from the access control system, GateKeeper turnstile control software, or push button device, the barrier arms will open and allow the user to pass through the turnstile in the direction requested. If an unauthorized user attempts to tailgate or enter from the opposite direction, the unit will recognize the illegal passage and the built in violation alarm will be activated.</p> <p>20 infrared sensors mounted inside the turnstile cabinets are used to monitor traffic through the turnstile and determine user position within the passageway.</p>
Proximity Card Reader Device Envelope	<p>Internal space is available for mounting of a mullion style proximity card reader device.</p> <p>The internal space available is 6-1/4" L x 2-3/4" W x 1-3/4" H.</p>
Status Icons	<p>An illuminated status icon display is flush mounted within the cabinet lid and is configured to function in the following manner:</p> <p><u>Yellow Card Icon:</u> Turnstile is ready for card presentation.</p> <p><u>Green Arrow Icon:</u> Passage is allowed in the direction indicated.</p> <p><u>Red Stop Icon:</u> Passage is prohibited in the direction indicated.</p>
“Open” / “Closed” Status Lights	<p>An illuminated status icon display is flush mounted within the cabinet end panel and is configured to function in the following manner:</p> <p><u>Green Arrow Icon:</u> The turnstile is “open” for use.</p> <p><u>Red Stop Icon:</u> The turnstile is “closed” for use.</p>
Arm Cycle Time	450 milliseconds
Status Chime	A chime tone indicates that an activation signal has been provided to the turnstile and the user is allowed passage.
Violation Alarm	A built in violation alarm will be activated when an unauthorized user enters the turnstile. Alarm duration is user configurable and can be set to sound continuously until manually reset or for a user defined time from 2 to 8 seconds. Alarm settings can be made via dip switches or with the GateKeeper turnstile control software.
Power Failure	The barrier arms of the SU3000-SM provide fail-safe operation and open automatically upon loss of power to the unit.
Emergency Breakaway	During emergencies the barrier arms of the SU3000-SM can be broken away in the vertical direction sounding the violation alarm.
Fire Alarm	Activation to open the barrier arms in conjunction with the fire alarm or other life safety system is achieved by supplying a sustained dry contact to the SU3000-SM. Terminal strip connections are provided for this purpose.

Interface	<p><u>Dry Contact:</u> Single passage activation for either direction of operation is achieved by supplying an isolated, voltage free, momentary dry contact duration of at least 500 ms. Separate terminal strip connections are provided for each controlled direction for passage allowed and passage denied input signals.</p> <p><u>RS-485:</u> Many turnstile settings, including passage activation, can be controlled and monitored using RS-485 serial interface and/or GateKeeper turnstile control software. Refer to the GateKeeper specification for additional information.</p>
Aborted Entry (Time Out)	Unit has an adjustable aborted entry (time out) timer. If the user does not pass through the turnstile within the set time, the turnstile will reset and wait for the next activation. If the user attempts to pass through the turnstile after the set time has expired the violation alarm will sound. Timer duration is user adjustable ranging from 5 to 20 seconds. Timer settings can be changed or disabled via dip switches or with the GateKeeper turnstile control software.
“Open/Close” Inputs	Activation to “open” or “close” either direction of passage is achieved by supplying a sustained dry contact to the SU3000-SM. Separate terminal strip connections are provided for each controlled direction for both “open” turnstile and “close” turnstile input signals.
Crawl Detection	4 of the 20 infrared sensors mounted inside the turnstile cabinets are used to prevent individuals from obtaining unauthorized passage by crawling through the passageway. Crawl Detection can be disabled via dip switches or with the GateKeeper turnstile control software if required for the application.
Blocked Sensor Alarm	The built in alarm will emit a chirping sound if one or more of the infrared sensors remains blocked or obstructed.
Tailgate Sensitivity	Tailgate sensitivity settings can be changed via dipswitches or with the GateKeeper turnstile control software.
Outputs	Terminal strip connections are provided for the following output signals: <p><u>Authorized Passage Feedback:</u> An isolated, voltage free, momentary dry contact output signal is provided for each direction of passage for each authorized user that passes through the turnstile.</p> <p><u>Unauthorized Passage Feedback:</u> An isolated, voltage free, momentary dry contact output signal is provided for each direction of passage for each unauthorized user that passes through the turnstile.</p> <p><u>Violation Alarm:</u> An isolated, voltage free, momentary dry contact output signal is provided each time the violation alarm is activated. This output allows the turnstile to be integrated with an external auxiliary security device such as a facility alarm, CCTV system, or an electric lock controlled door when the turnstile is violated.</p> <p><u>Aborted Entry (Time Out):</u> An isolated, voltage free, momentary dry contact output signal is provided for each direction of passage every time passage is aborted.</p>
Power Supply	120 VAC, 60 Hz
Power Rating	Maximum power consumption is 250 W per turnstile.
Operational Voltage	Primary power is stepped down and rectified for low voltage 48 VAC, 12 VDC, and 5 VDC operation.

Installation Details SU3000-SM turnstile cabinets are shipped fully assembled. Fork lift & pallet jack equipment is required for off loading.

Approximate Weight End Cabinet approximately 275 lb. (125 Kg) per cabinet
Center Cabinet approximately 325 lb. (150 Kg) per cabinet

Cabinet Types Available

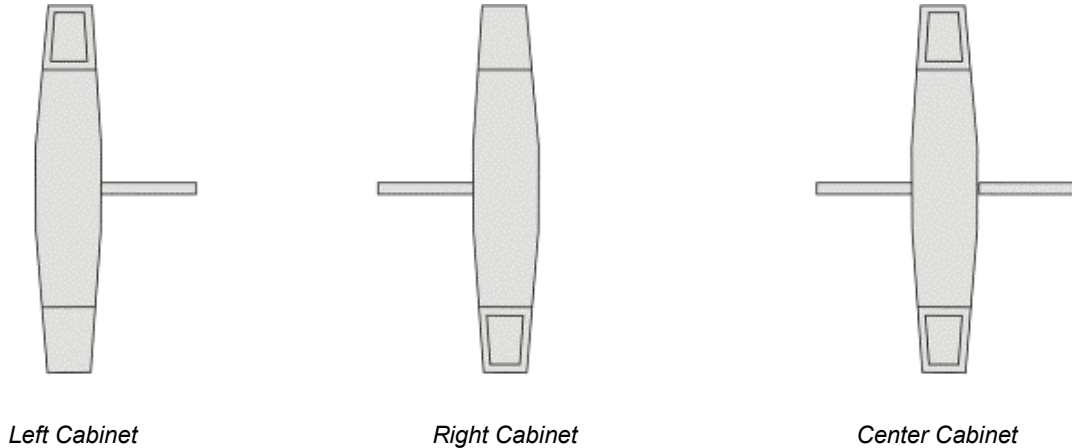

Options

Alternative Cabinet Materials and Finishes

- Fine wood cabinets constructed from hardwood (end panels) and wood veneer (side panels):

- Red Oak	- Pecan	- Beech	- Teak	- Red / Pink Birch
- Maple	- Walnut	- Alder	- Cherry	- Knotty Pine
- Mahogany	- White Oak	- White Birch	- Standard Birch	- Wegue

Hardwood finishes:

- Clear Natural - Oil Stained - Air Brushed & Glazed

- Any commonly available laminate



Alternative Lid Colors and Materials

- Samsung Staron® alternate colors - (see available colors at www.staron.com)
- Dupont™ Zodiac® quartz - (see available colors at www.zodiac.com)
- Natural marble - (contact Alvarado for available colors)

Card Rejection Beeper

A beeper indicates that a rejection signal has been provided to the turnstile and the user is denied passage.

“Open” / “Close” Turnstile Overrides

A built in key override switch overrides the access control system to “open” or “close” one or both directions of the turnstile. Separate overrides are required for each direction of passage.

GateKeeper Turnstile Control Software

Password protected PC based program allows all installed SU3000 turnstiles to be configured, monitored and administrated, allowing control of virtually all turnstile functionality, from a single standard PC. Communicates with the SU3000 units via RS-485 serial communication. Program runs on Windows 2000 or XP operating system.

Alternate Power Supply

100/240 VAC, 50/60 Hz

Horizontal Emergency Breakaway

During emergencies the barrier arms can be broken away in the horizontal direction sounding the violation alarm and disabling the motors.

- Arm knuckle allows each arm to breakaway 90°
- Arm can be broken away in either the entrance or the exit direction
- Return the arms to normal operating position and reset the alarm to resume normal operation



SU3000-SM General Configuration

Single Lane Configuration

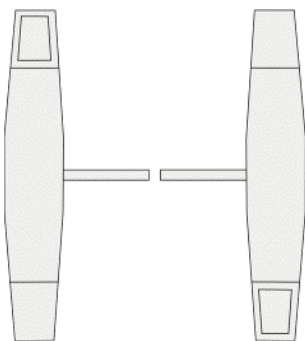

Multi Lane Configuration

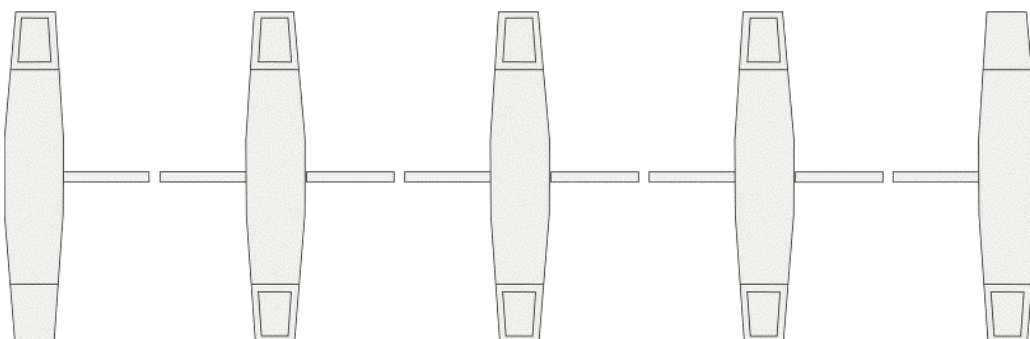

Status Icon User Instructions



Yellow Card

- Turnstile is ready for card presentation
- Present access control card to the reader for authorization
- Wait for the Green Arrow to illuminate and the barrier arms to open



Green Arrow

- Passage is allowed in the direction indicated
- Proceed through the turnstile



Red Stop

- Passage is prohibited in the direction indicated
- Wait for the Yellow Card to illuminate before presenting the next access control card to the card reader



Flashing Green Arrow

- Free passage is allowed in the direction indicated
- An access control card is not required in the direction indicated
- Proceed through the turnstile

“Open” / “Closed” Status Light User Instructions



Green Arrow

- Turnstile is “open” for use
- Present access control card to the reader for authorization



Red Stop

- Turnstile is “closed for use”



Flashing Green Arrow

- Turnstile is “open” for use
- Free passage is allowed in the direction indicated
- An access control card is not required in the direction indicated
- Proceed through the turnstile

Alarm Conditions

The alarm will be activated in each of the following scenarios:

- Unauthorized Passage
- Premature Entry
- Tailgating
- Loitering
- Crawl Violation
- Gate Crashing

Flashing Red Stop Status Icon and Audible Alarm



Flashing Red “Closed” Status Stop End Light and Audible Alarm (Option)



SU3000-SM Site Preparation

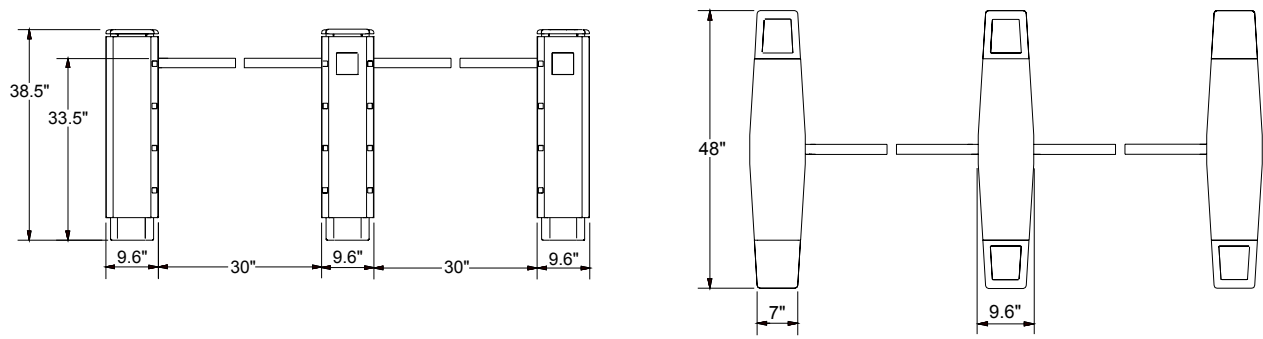

SU3000-SM Footprint Drawing

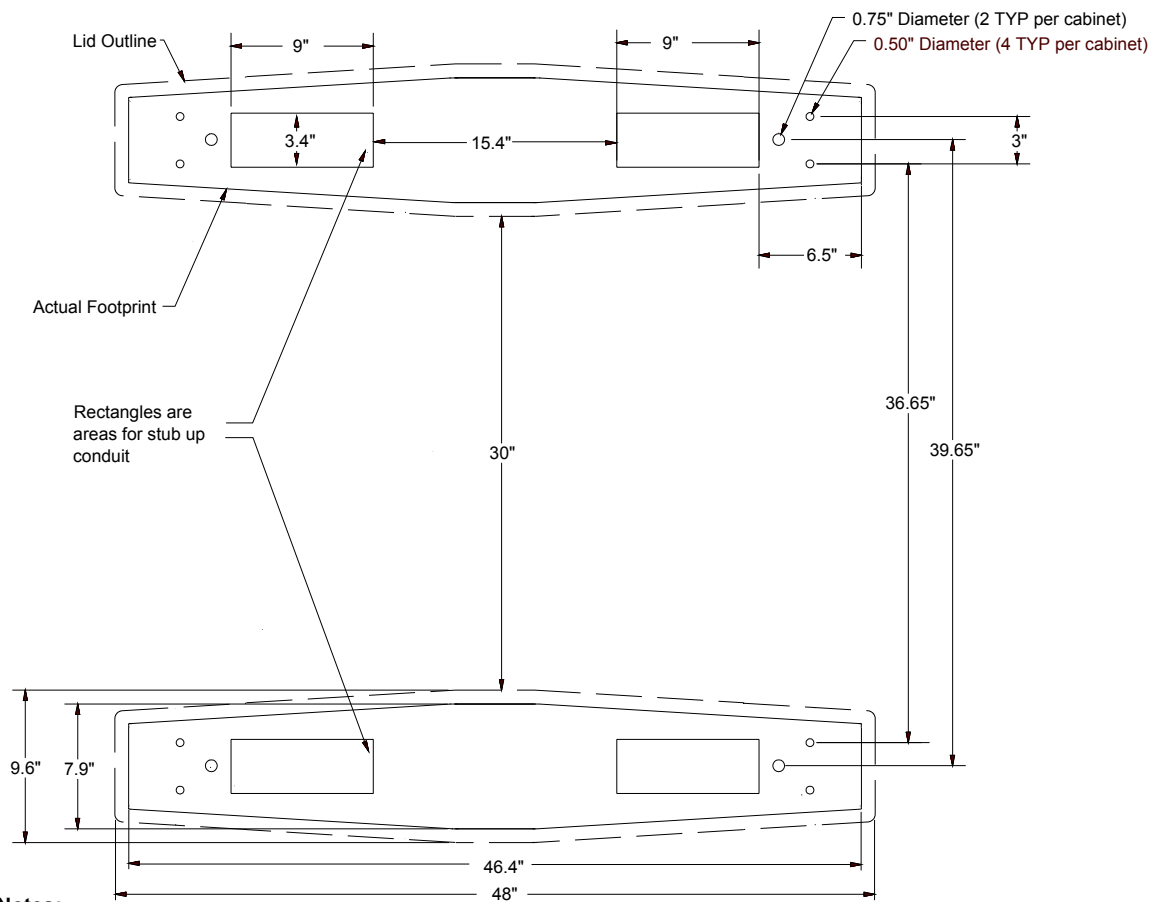

Notes:

- The cabinet centerline to centerline dimension for a Standard 30" passage width is 39.65".
- The cabinet centerline to centerline dimension for an ADA Compatible 36" passage width is 45.65".
- For custom installations that deviate from the Standard and ADA Compatible lane passage widths, the passage width of the lane must never exceed 36" (this is measured from the inside edge to edge for a clear passage width).

Slab Requirements

- Minimum thickness 4" (102 mm) level solid concrete pad
- A full sweep electrical conduit underneath the floor, one for power and another for communication, separated from each other.
- Cabinets must be installed perpendicular and flush with the floor while level to each other.

Conduit Requirements

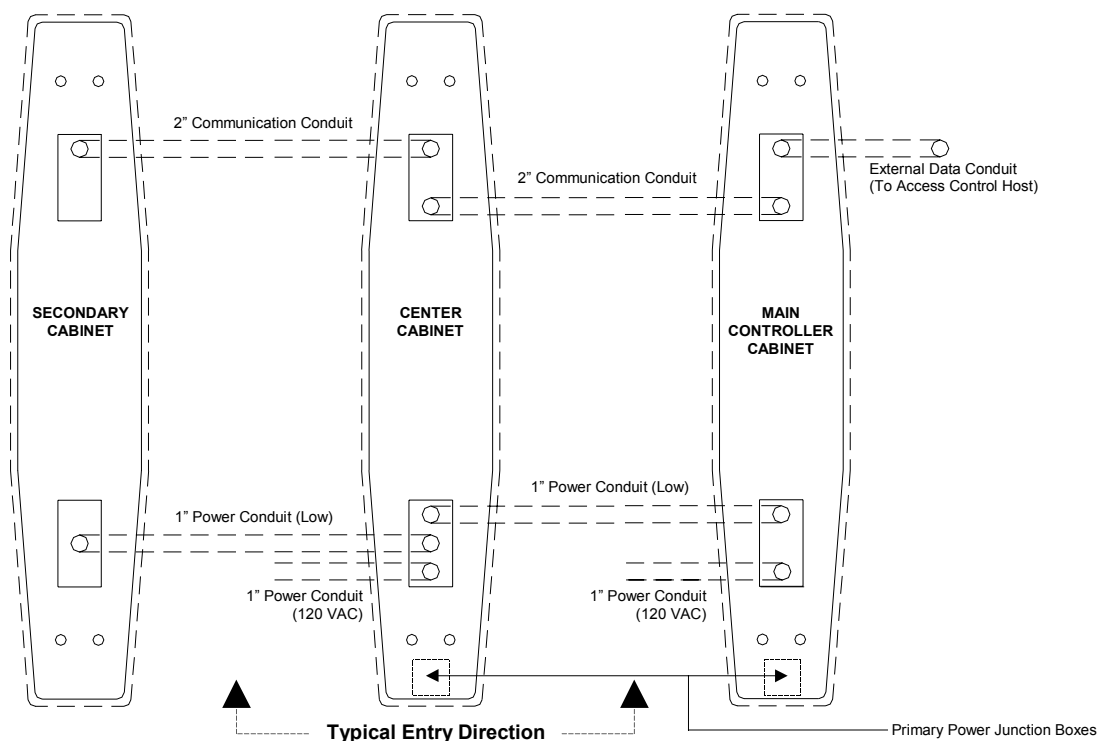

High Voltage Power Conduit

- 1" power conduit for 120 VAC primary power must be run to the Main Controller Cabinet and each Center Cabinet.

Low Voltage Power Conduit

- 1" conduit must be run to interconnect the cabinet sets that form each passage lane.
- The power cables required to interconnect the cabinet sets that form each passage lane are provided with the turnstiles. Do not roll excess cabling.
- Conduits that interconnect a cabinet set can not exceed 10' in length.

Communication Conduit

- 2" conduit must be run to interconnect the cabinet sets that form each passage lane.
- The ribbon cables required to interconnect the cabinet sets that form each passage lane are provided with the turnstiles. Do not roll excess cabling.
- Conduits that interconnect a cabinet set can not exceed 10' in length.

Access Control System Conduit

- Diagrams provided do not specify the conduit requirements for integrating the turnstile with an access control system.
- Consult access control system provider for power and communication conduit specifications for integrating card readers or other access control system devices with turnstiles.

GateKeeper Turnstile Control Software RS-485 Serial Interface Conduit Requirements

Turnstile settings, including passage activation, can be controlled and monitored using RS-485 serial interface and/or GateKeeper turnstile control software. Four wire communication cable must be daisy-chained from the COM port on the host computer to each turnstile to provide RS-485 communication.

- No more than 16 turnstiles may be daisy-chained to each COM port
- Total cable length from the COM port to the last turnstile in the daisy-chain may not exceed 3000 feet (914 m)
- RS-485 communication cable must not be run in the same conduit as AC Power

Single COM Port RS-485 Daisy-Chain Cabling Diagram

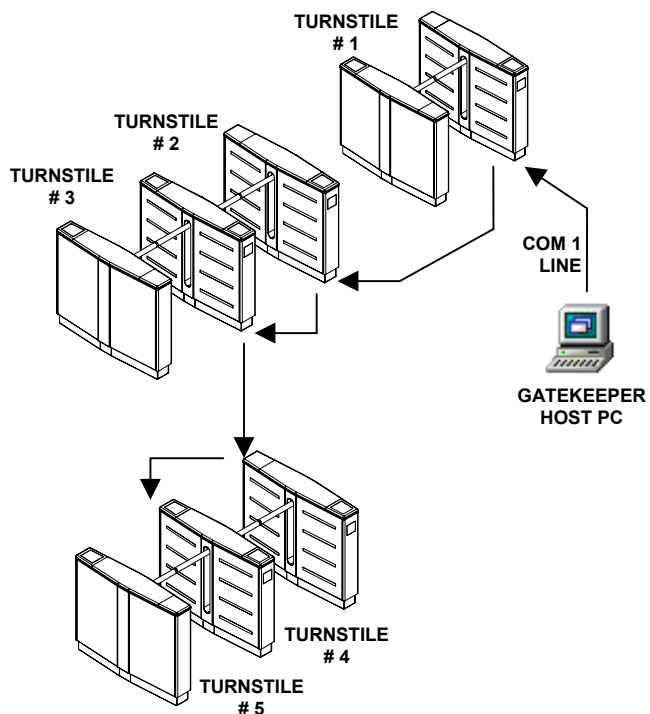

Multiple COM Port RS-485 Daisy-Chain Cabling Diagram

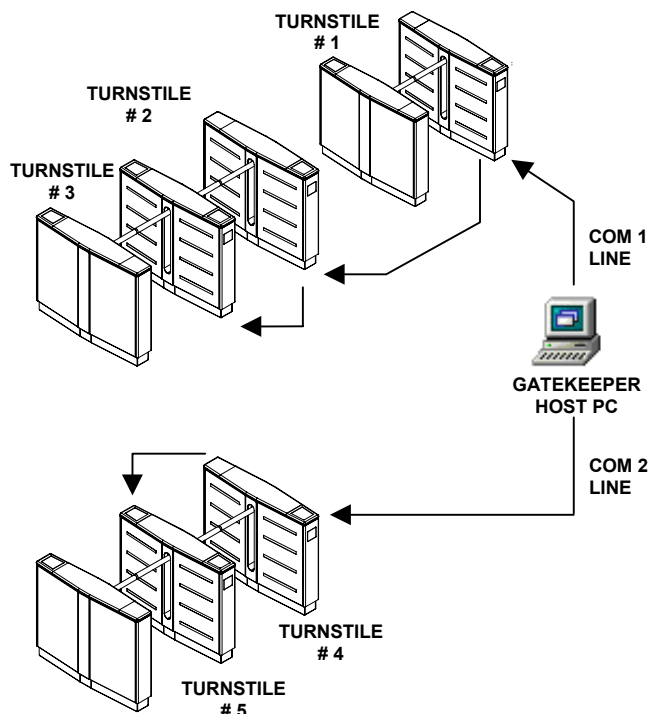

Throughput Rates

<u>Card Reader Device</u>	<u>Users per minute</u>
Proximity	40
Magnetic Swipe	25
Magnetic Swipe with Numeric Keypad	20
Omni-directional Barcode Scanner	40

- Figures are approximations
- Flow rates may increase with enhanced user familiarity
- Access control / card reader system response time is assumed to be instantaneous

ALVARADO

Alvarado Manufacturing Company, Inc.
12660 Colony Street
Chino, CA 91710

Telephone (909) 591-8431
Toll Free (800) 423-4143
Fax (909) 628-1403

www.alvaradomfg.com