

POST AND RAIL

Product Name:

Post and Rail

Manufacturer

Alvarado Manufacturing Co. Inc.

12660 Colony St.

Chino, CA 91710

Telephone (909) 591-8431

Toll Free 800-423-4143

Fax (909) 628-1403

www.alvaradomfg.com

Email: Information@alvaradomfg.com



Product Description: Alvarado offers a complete line of post and railing components designed for strength, durability, and aesthetic appeal. Our railing systems provide directional control and security, in addition to a wide variety of custom applications. Railing systems are available in standard double and triple rail configurations to meet varying security needs.

Components:

- **Posts** - Alvarado offers a variety of fixed and removable posts to suit different applications. A base cover and post cap is included with most posts. Anchoring packages are available, but not included. See the specification for the different post types for more information.
- **Rails** – Horizontal rails are 1.75" OD made from 16-gauge steel and are available in 6" increments from 1' to 10'.
- **Rail Outlets** – Factory installed 1.79" ID x 0.34" thick x 1.69" long zinc casting tubes with the appropriate finish. Each outlet includes a 0.25" set screw to hold rails in place. Outlets are installed 14" apart from each center.

Rail Outlet Configuration: Standard railing outlets are positioned as follows:

- **Double Rail** – Two outlets are installed on a 35" post. The bottom outlet is 19.5" from the floor to its center and the top outlet is 33.5" from the floor to its center.
- **Triple Rail** – Three outlets are installed on a 44" post. The bottom outlet is 14.5" from the floor to its center, the middle outlet is 28.5" from the floor to its center, and the top outlet is 42.5" from the floor to its center (Only available in bright chrome finish).

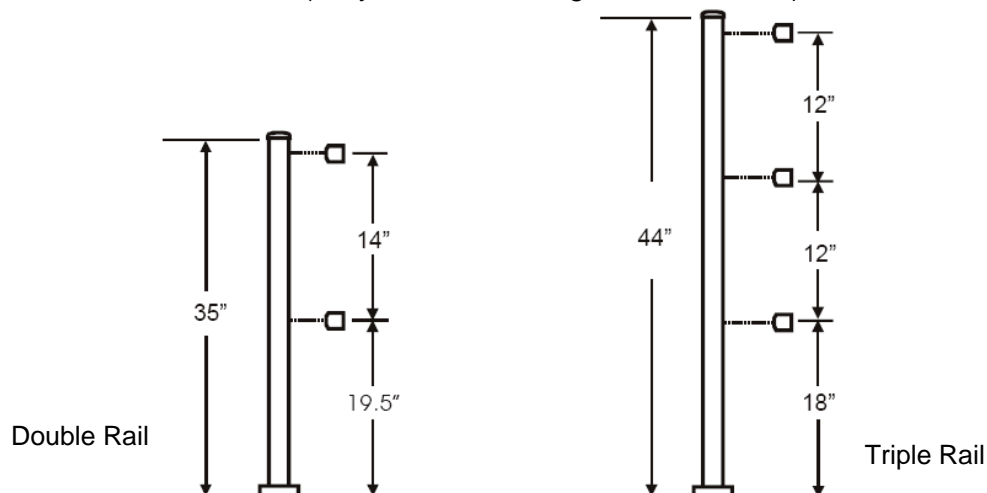

Finishes: Posts and Rails may be offered in the following finish:

- **Bright Chrome** – All external fabricated materials are composed of chrome plated steel, polished to a mirror finish.
- **Stainless Steel** – All external fabricated materials are composed of stainless steel polished to a #4 satin finish.
- **Powder Coated** – All external fabricated materials are composed of steel, powder coated to a variety of different colors.

Size: Posts are available in different heights depending on the post type. See the specification for the different post types for more information.

Options: Posts are available with the following options:

- **Anchor Package** - Consists of four (4) SB-14 anchors with 3/8-16 x 2½” HHCS and washers. Each SB anchor is a 2” long x 5/8” diameter single-expansion system that expands to lock the anchor bolt securely in place.

Shipping: Most Posts are shipped ready for installation. Posts and Rails are sold separately. Alvarado ships products throughout the world.

Installation: All Posts must be installed on level concrete. Installation should be performed by a skilled installer following the manufacturer’s instructions. Installation instructions are included with each post.

Warranty: Alvarado Manufacturing Co., Inc. warrants all Posts and Rails from defects in material or workmanship, for the period of ONE YEAR from the date of shipment. Complete details of the warranty are available from Alvarado by request.

Technical Services: Technical information is available from Alvarado Mfg. Co., Inc., and its representatives, distributors, and dealers.