

ALVARADO

CLSTX

Clear Yoke Maximum Security Turnstile



Technical Specifications

Dimensions	<u>Unit Height:</u>	92.5" (2350 mm)
	<u>Unit Width:</u>	62.25" (1581mm)
	<u>Unit Depth:</u>	54.125" (1375 mm)
Materials	<u>Yoke:</u> (Curved Section)	Two piece assembly consisting of 3/16" thick polycarbonate panel contained within an extruded aluminum frame. Each frame consists of two 1 3/4" wide vertical pieces and two 3 3/8" wide horizontal pieces bent to a centerline radius of 29 3/8". The polycarbonate panel section also has a centerline radius of 29 3/8" and is securely contained within the inside perimeter of the frame. Available in #4 satin or powder coated finish.
	<u>Yoke Guard Plate:</u>	Cold rolled steel (or #304 stainless steel). 16-gauge sheet bolted to the top of the channel / yoke assemblies.
	<u>Roto:</u> (Rotating Section)	Formed and welded cold rolled steel (or #304 stainless steel). Each arm is constructed from 1-3/4" OD x 14-gauge tubing, notched and welded to a vertical 3" OD x 3/16" wall tube, and capped with a 1-3/4" OD x 10-gauge cap. The roto contains 13 arms per section for a total of 39 per roto. No external fasteners are used in the construction of the rotos. All exterior welds are ground smooth and polished. Available in #4 satin or powder coated finish.
	<u>OV:</u> (Barrier Section)	Formed and welded cold rolled steel (or #304 stainless steel). Consists of 13 1-3/4" OD x 14-gauge tubing notched and welded at one end to a vertical 3" OD x 3/16" wall tubes, and capped with a 1 3/4" OD x 10-gauge cap. No external fasteners are used in the construction of the OV. All exterior welds are ground smooth and polished. Available in #4 satin or powder coated finish.
	<u>Top Channel:</u>	Formed and welded 304 stainless steel. The "U" channel is composed of 10-gauge steel with a 16-gauge cover. All exterior welds are ground smooth and polished. Available in #4 satin or powder coated finish.
	All tubing and sheet metal materials meet ASTM Standard A513.	
Function	The CLSTX is an electric lock controlled, full height turnstile designed to provide controlled access into and out of high security facilities.	
Available Configurations	The CLSTX is designed to interface with virtually any access control system or reader to provide the electric locking control required in controlled access facilities. The following configurations of the CLSTX are available:	
	CLST-3	Using key lock control, the CLST-3 can be configured to provide free passage in both directions; free passage in one direction and restricted passage (locked) in the opposite direction; or restricted passage (locked) in both directions.
	CLSTX-5X	Electric lock control in one direction, free passage in the opposite direction. This model includes self-centering roto operation.
	CLSTX-6X	Each turnstile has separate electric lock controls in both directions.

Control Mechanism Components

Cam and Shaft Assemblies

The lobed cam is precision investment cast stainless steel welded to a splined shaft. The splined shaft fits into a reciprocal splined coupling in the top of the roto, creating a solid non-slip connection between the parts.

Top Bearing Assemblies

Each cam and shaft assembly rotates in a bearing assembly consisting of two fully protected precision bearings.

Friction Brake Assemblies

The braking mechanism consists of a precision investment cast steel circular disc brake that rotates and maintains contact with two disc brake pads to provide friction braking during the rotation of the turnstile. The friction braking tension is adjustable.

Mechanical Turnstile Control

The locking and unlocking of the unit is controlled with stainless steel lock arms that are moved into the appropriate locked or unlocked position by continuous duty rated solenoids and spring assemblies. There is one solenoid and spring assembly per lock arm, and one lock arm per direction, allowing for independent control of each rotational direction.

Opto Interrupter Rotation Wheel Assembly

This assembly consists of two opto-interrupters (small, industrial grade, transmit and receive LEDs), and a rotation wheel. As the turnstile arm is rotated, the rotation wheel passes between the two opto interrupters, signaling the Alvarado Turnstile Controller (ATC) that a turnstile rotation has occurred. The ATC uses this information to re-lock and provide access control functionality without the need for mechanical microswitches.

Electrical Components and Functionality

The following are the electrical requirements and standard functionality of the CLSTX:

Power Supply

110 VAC, 60 Hz

Low voltage primary power of 10 VAC or 13.5 VDC may also be supplied by connecting power directly to each ATC.

Power Rating

Maximum power consumption is 75 W per turnstile.

Operational Voltage

Primary power is stepped down and rectified for low voltage 12 VDC operation.

On/Off Switch

An on/off switch is located on each power junction box inside the CLSTX top channel. A visible green LED is illuminated on the ATC when the power is "on".

Power Receptacles

The power junction box inside the CLSTX top channel includes two 110 VAC power receptacles providing a convenient way for installers or technicians to power tools or equipment they may need as they test or maintain the CLSTX in the field.

Surge Protection

Each ATC has line to line surge protection for single-phase low voltage AC input to 125 amps. Each ATC also contains a varister that switches to a high impedance state to protect the circuit in the event of a power surge.

Bi-directional Solenoid Drivers

Each ATC provides one solenoid driver per rotation direction.

Activation

Activation for either direction of operation is achieved by supplying a momentary dry contact of any duration to the ATC. A terminal strip connection is provided on the ATC for this purpose.

Timed Delay Auto Re-Lock

An activation signal unlocks the turnstile for one entry. Once the turnstile is unlocked, the user is allowed a maximum of 20 seconds to pass through the turnstile. If the turnstile arms are not rotated within the 20-second time frame allowed, the turnstile automatically relocks.

Field Activation Testing

Each ATC provides a field activation testing button, for each electrically controlled direction. This feature provides a simple way for installers to test the functionality of the CLSTX and isolate problems in the field.

Remote Unlocking Each ATC accepts inputs from a continuous dry contact emitting device to bypass the access control system and allow the CLSTX to be remotely unlocked or “opened” in the electrically controlled direction(s). A terminal strip connection is provided on the ATC for this purpose.

Outputs Terminal strip connections are provided for the following output signals:

Feedback / Turnstile Rotation Count The ATC provides a double pole, single throw, relay in each direction of operation. This allows the ATC to provide a “feedback” signal in the form of a relay output to the access control provider or an external counting system. A terminal strip connection is provided on the ATC for this purpose.

Available Finishes **Powder Coated** Available in a wide variety of colors. Sub-assemblies are sand blasted to prepare for the powder coating finish. The powder is electrostatically applied, then baked to assure proper curing and adhesion.

Stainless Steel All external fabricated materials are composed of #304 stainless steel (noted in the descriptions above as #304 SS) and polished to a #4 satin finish.

Shipping Details CLSTX turnstiles are shipped in six main sections: the Top Channel, the Yoke section (shipped as 2 half yokes), the Roto, the OV, and the Yoke Guard Plate. Each section is fully fabricated as a sub-assembly for easy installation. Each CLSTX unit includes mounting hardware (anchors, bolts, washers, etc.) to mount the unit to a standard concrete pad. Alvarado ships products throughout the world.

Installation Details All CLSTX units must be installed on a firm foundation in a manner that allows the required power and activation signal cabling to be pulled into the top channel. The recommended platform is 72” square by 4” deep, level concrete. No embedded fasteners are needed for installation. Installation should be performed by a skilled installer following the manufacturer’s directions and instructions (supplied with the turnstile).

Approximate Weight Approximately 720 lb. (327 Kg) per turnstile.

Options

220 VAC

A 220 VAC, 50-60 Hz power supply is provided. 220VAC units bear CE marking, except for battery backup capability which is not available on CE marked units.

Failsafe Operation

The electrically controlled direction(s) will unlock upon power loss and provide free passage. The CLSTX unit is supplied in a fail-lock mode as standard. If power is interrupted to a standard fail-lock CLSTX, it will remain locked in the electrically controlled direction(s). Failsafe operation can be specified for one or both electrically controlled directions.

Card Reader Mounting Plate

One or more mounting plate(s) can be provided to allow the access control reader and/or key pad to be mounted on the yoke of the CLSTX turnstile if desired.

Push Button Assembly

This option allows the user to unlock the turnstile for one passage with a stainless steel push button assembly. This option is most commonly used in the exit directions of Model CLSTX-6X units.

Key Overrides

A key override allows the operating technician to override the access control system and unlock one or both directions of the CLSTX turnstile. Key overrides may be either mechanical or electrical (depending on the operation of the turnstile). Separate key overrides are required for each direction of travel and are located on the underside of the top channel. When both directions have key overrides, the locks are keyed alike.

Extended Function Turnstile Controller (ATC-FB)

The extended function turnstile controller (ATC-FB) expands the option selection and provides additional functions such as:

- **Adjustable Timed Delay Auto Re-Lock**

This option allows the operating technician to adjust the duration of the time allowed for the user to pass through the turnstile in each controlled direction. If the turnstile arm is not rotated within the time frame set, the turnstile will automatically re-lock. This option also allows the operating technician to disable the timed delay auto re-lock feature if desired. Adjustments to the timed delay auto re-lock feature can be made in one or both directions for CLSTX units configured to provide bi-directional electric lock control.

- **Remote Locking**

The ATC-FB accepts inputs from a continuous dry contact emitting device to bypass the access control system and allow the CLSTX to be remotely locked or “closed” in the electrically controlled direction(s).

Red/Green Card Status Lights (Not Available with the Extended Function Turnstile Controller)

Red and Green LEDs are available for use with the CLSTX unit. The red and green LEDs are configured to function in the following manner:

- An illuminated red light indicates the turnstile is locked and ready for card presentation. The red light will remain illuminated if an “unauthorized” card is presented.
- An illuminated green light indicates that the access system has provided the ATC with an activation indicating that an “authorized” card has been presented. When the green light illuminates, the turnstile will unlock.

Red/Green/Yellow Card Status Lights (Available with ATC-FB Turnstile Controller Equipped Units ONLY)

Red, Green, and Yellow LEDs are available for use with the CLSTX unit. The red, green, and yellow LEDs are configured to function in the following manner:

- An illuminated yellow light indicates the turnstile is locked and ready for card presentation.
- An illuminated green light indicates that the access system has provided the ATC with an activation indicating that an “authorized” card has been presented. When the green light illuminates, the turnstile will unlock.
- An illuminated red light indicates that the access system has provided the ATC with an activation indicating that an “unauthorized” card has been presented. The turnstile will remain locked. To accommodate this feature an additional terminal strip connection is provided on the ATC for each controlled direction.

Turnstile Open/Closed Lights (Available with ATC-FB Turnstile Controller Equipped Units ONLY)

Large Red and Green lights are also available to indicate whether the CLSTX turnstile is open or closed. This option is used in conjunction with the remote locking and unlocking option.

Speed Control w/ Self Centering

Self-adjusting speed control automatically increases or decreases resistance depending on the pushing force exerted by the user. The speed control provides a smooth even rotation under normal operating conditions. Self-centering corrects under or over rotation of the turnstile arms and automatically returns the roto section to the “home” position (one set of arms pointing directly at the center of the yoke). This feature is standard on the CLSTX-5X.

Self-Centering Mechanism

The self-centering mechanism corrects under (less than 120°) or over (more than 120°) rotation of the turnstile arms following completion of a passage cycle. The turnstile arms automatically return to the "home" position (with one set of arms pointing directly at the center of the yoke) when this option is installed. This feature is standard on the CLSTX-5X.

Battery Backup

A trickle charge battery system is installed in the top channel to provide turnstile operation if primary power is lost.

Heel Guards

Padded foam sleeves for the lower roto arms. Heel guards are packaged three to a set and are used to cushion the lowest arms on the roto.

Arm Guards

Padded foam sleeves for the higher roto arms. Arm guards are packaged three to a set and are used to cushion the higher sets of arms on the roto.

Top Channel Stabilizer

A top channel stabilizer can be provided to add rigidity between the OV and top channel assemblies.

Computerized Counting

Each turnstile rotation outputs a count to GateWatch, Alvarado's Windows based software program that monitors and records real time patron counts. Counts can be transmitted from the turnstile in several ways, including over a standard, in facility, Ethernet network or using wireless RF devices.

Out of Service Lock Bracket

Enables the turnstile to be secured with a padlock when out of service.

CLSTX Site Preparation

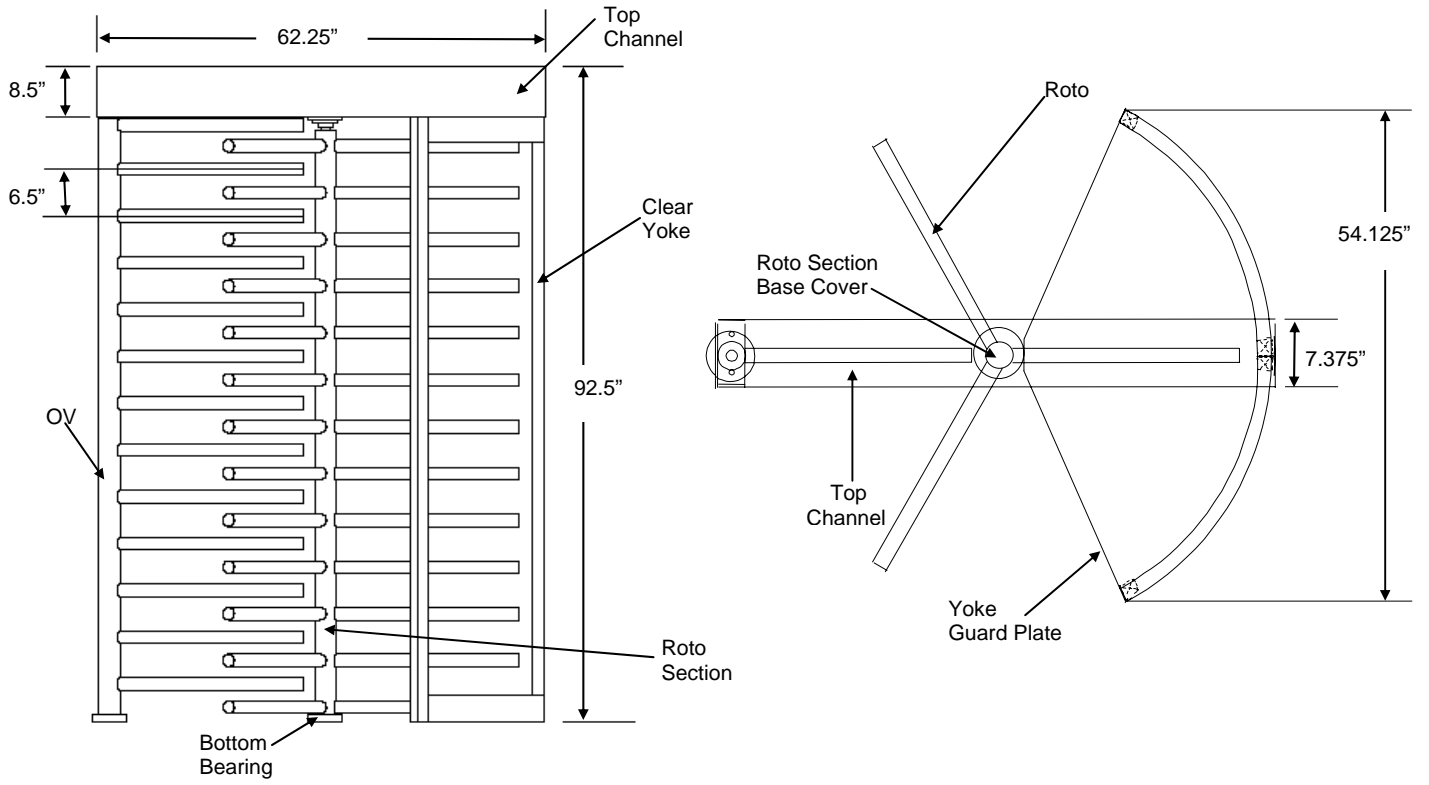

CLSTX Footprint Drawing

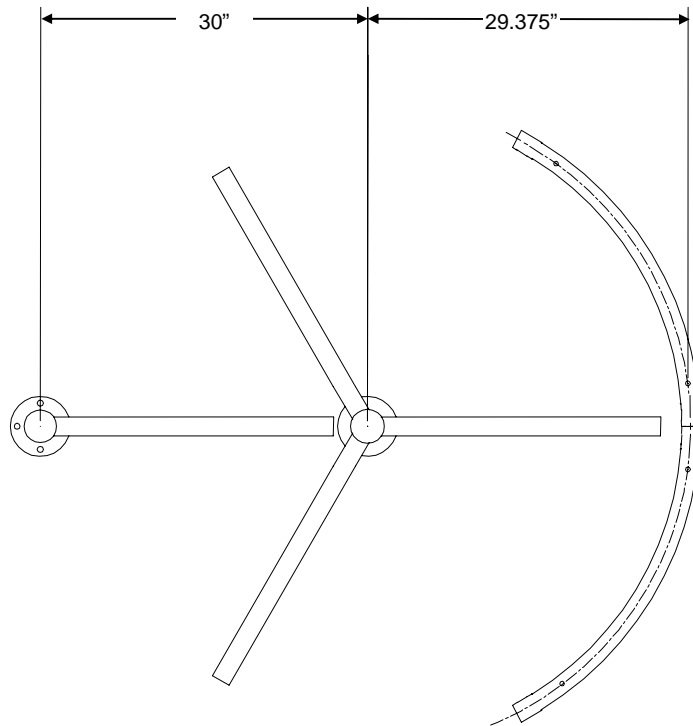

Anchor Pattern

ROTO and OV Base

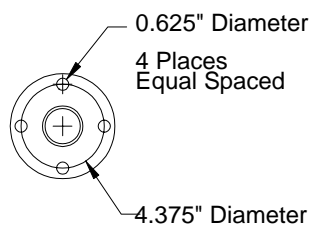

Slab Requirements

- Minimum 72" square by 4" deep, level solid concrete pad
- Optional conduit run may be done through the OV base

Warranty

Alvarado Manufacturing Co., Inc. warrants the CLSTX, from defects in material or workmanship, for the period of ONE YEAR from date of shipment. Complete details of the warranty are available from Alvarado by request.

Technical Services

Technical information is available from Alvarado Manufacturing Co., Inc., and its representatives, distributors, and dealers.

ALVARADO

Alvarado Manufacturing Company, Inc.
12660 Colony Street
Chino, CA 91710

Telephone (909) 591-8431
Toll Free (800) 423-4143
Fax (909) 628-1403



www.alvaradomfg.com