

SSB

Product Name

Stainless Steel Bumper – Model SSB

Manufacturer

Alvarado Manufacturing Co., Inc.

12660 Colony St.

Chino, CA 91710

Telephone (909) 591-8431

Toll Free 800-423-4143

Fax (909) 628-1403

www.alvaradomfg.com

Email: information@alvaradomfg.com

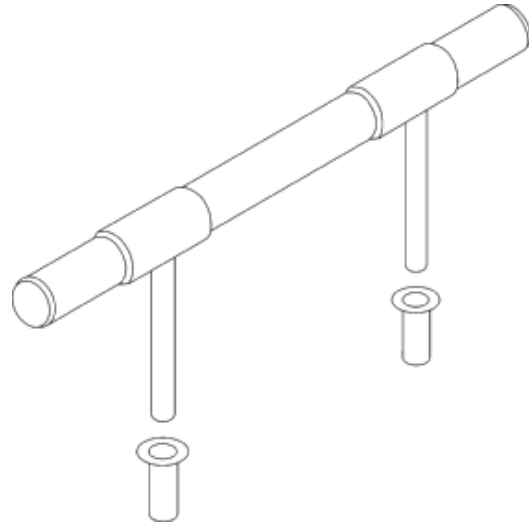

Product Description: The SSB bumper is designed to provide removable case and wall protection.

Components:

- The **SSB Rail** is constructed of 1.75” diameter x 16-gauge stainless steel tubing capped at each end with a force fit, impact resistant plastic end cap designed to fit and adhere tightly into the rail. The top of the rail sits 7.125” above the floor.
- The **SSB Stem** is a fully welded assembly constructed of a tapered 2” diameter x 4” long stainless steel tube welded to a 0.75” diameter x 7.5” long stainless steel rod. All welds are ground smooth. Two (2) 1/4-20 set screws are provided on the underside of each SSB Stem assembly to secure the stem to the SSB Rail. The stems extend 7.75” past the steel tube and fit smoothly into the floor sockets.
- The **SSB Socket** is a 0.755” I.D. x 2.5” long stainless steel tube with a 1.75” diameter flange at one end and sealed at the other end.

Finishes: The SSB Bumper is available in the following finish:

- **Stainless Steel** – All external fabricated materials are composed of stainless steel and polished to a #4 satin finish.

Size: The SSB Bumper has an overall height dimension of 9.5” (7.125” above the floor when installed) and are available in knock down assemblies in one- (1) foot increments from 1’ to 12’ lengths. The number of SSB Stems attached with each unit is dependent upon the length of the SSB Bumper. The following table shows the number of rails and their lengths and stems according to the final length of each SSB Bumper.

Length	1’	2’	3’	4’	5’	6’	7’	8’	9’	10’	11’	12’
Rails	1-12”	1-24”	1-36”	1-48”	2-30”	2-36”	2-42”	2-48”	3-36”	2-36” 1-48”	2-48” 1-36”	3-48”
Stems	2	2	2	2	3	3	3	3	4	4	4	4

Shipping: SSB Bumpers are shipped in knock down assemblies. Each SSB Bumper includes socket hardware to mount the unit to a standard, level concrete floor. Alvarado ships products throughout the world.

Installation: All SSB Bumpers must be installed on level concrete. Installation should be performed by a skilled installer following the manufacturer's instructions (included).

Corner Section Configurations:

The following is a list of corner section SSB Bumper configurations that are available:

- **90° SSB** – The SSB Rail is bent to a 90° angle with a 6" radius. The 90° SSB provides 12" of case protection coverage on each side of the bend. Two (2) stems are provided with each 90° SSB. Socket hardware is included.

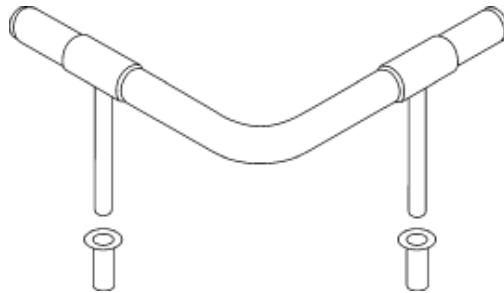

- **135° SSB** – The SSB Rail is bent to a 135° angle with a 6" radius. The 135° SSB provides 12" of case protection coverage on each side of the bend. Two (2) stems are provided with each 135° SSB. Socket hardware is included.

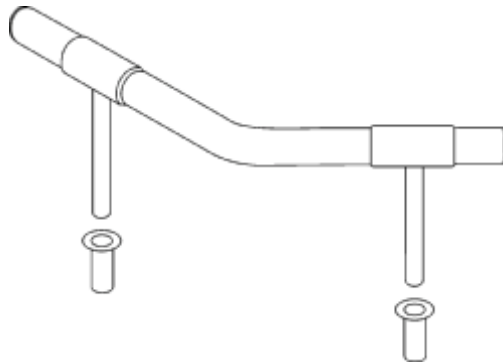

Warranty: Alvarado Manufacturing Co., Inc. warrants the SSB bumper from defects in material or workmanship, for the period of ONE YEAR from date of shipment. Complete details of the warranty are available from Alvarado by request.

Technical Services: Technical information is available from Alvarado Mfg. Co., Inc., and its representatives, distributors and dealers.