

Alvarado's VSG gates are an attractive, simple, solution to provide handicapped and parcel delivery at controlled entry points. Generally installed adjacent to turnstiles, VSG gates integrate with Alvarado's prefabricated stainless steel railing and turnstiles to provide a complete entry solution.

VSG gates come in two versions. The VSG-1 is a manual (no lock) gate that swings in one direction. The VSG-1 opens smoothly and closes slowly, minimizing the slamming encountered with competitors gates.

The VSGX-1 has the same smooth opening and closing action, but adds an electric

(magnetic) lock that locks the gate in the home position. The VGSX-1 unlocks through use of a push button (available from Alvarado), or the gate can integrate with your access control system.

Gates are available with a clear acrylic panel and wheelchair logo sticker or with steel infill bars.

VSG gates are fabricated from stainless steel. The standard finish is #4 satin (brushed satin). A bright #8 (mirror) finish is also available.



Shown with Acrylic Panel

- **Wheelchair Accessible**
- **Attractive Design**
- **No Lock & Electric Lock Controlled Models**

Shown with Infill Bars



ALVARADO



PRODUCT NAME

VSG-1 and VSGX-1 waist high gates

APPLICATIONS

Used in conjunction with turnstiles and post and railing in facilities requiring material delivery or disabled access.

PRODUCT FEATURES - Mechanical

Materials and Operation

- Fabricated from stainless steel
- Kick plate
- Self closing
- Hydraulic dampener
- Gate hinge and latch posts attach securely to the floor with expansion anchors

Finishes

- Stainless steel polished to a #4 satin finish
- Stainless steel polished to a #8 mirror finish

PRODUCT FEATURES - Electrical

Electric

- Primary power is stepped down and rectified for low voltage 12 VDC operation
- 120 VAC input step down transformer is included

Electric Locks/Activation

- VSGX-1 gates use a 600 lb. holding force magnetic lock
- Gate is activated (unlocked) when power is removed
- Gate relocks after gate arm closes and power is restored
- VSGX gates are "Fail Safe" — they will unlock upon loss of power

VSG(X) OPTIONS

Infill Style - Gate may be ordered with infill bars or a clear acrylic panel.

Push Bar - Electric push-release bar opens gate for emergency exit. (Available on VSGX-1 infill bar version only)

Remote Activation - Normally open push button or key switch provides an "unlock" signal from remote location.

WARRANTY

Alvarado's standard one-year written warranty applies to all products.

VSG(X) Dimensions

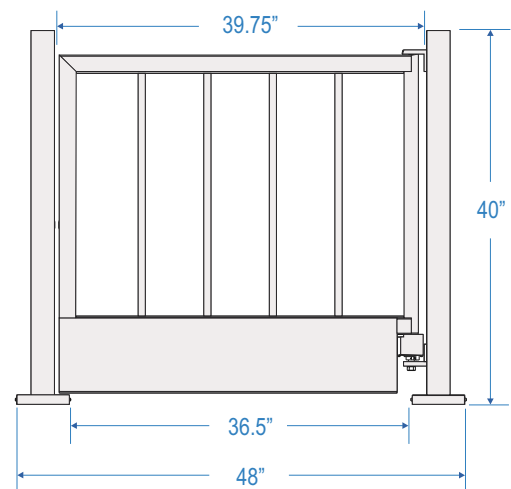

*NOTE: Dimensions are approximate.

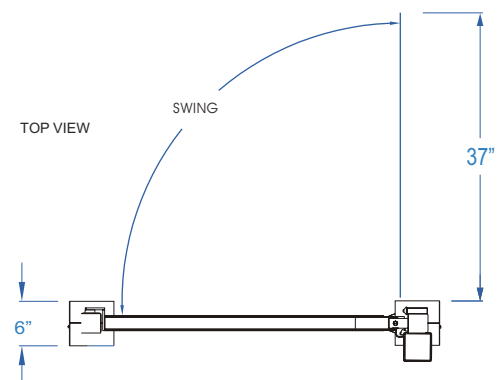

*NOTE: Right hand swing shown.