

MODEL SU3500  
**SUPERVISOR 3500**  
BARRIER WING

# OPTICAL TURNSTILES

alvaradomfg.com

The Supervisor 3500 combines motorized barrier wings, superior optical technology and beautiful cabinetry for a state-of-the-art optical turnstile suitable for any upscale facility.

The SU3500 has two bi-directional access controlled operational modes.

In *normally closed mode*, a valid ID is presented, a pleasant chime sounds and a green arrow icon illuminates in the direction of travel. The acrylic panels smoothly retract, allowing a single patron to pass. After passage, the wings return to the closed position. Cycle time is less than 1/2 second.

In *optical mode*, the wings are permanently retracted and the unit operates as a barrier free optical turnstile. An alarm sound and visual notification is provided if passage is attempted without the presentation of a valid credential. Additional "good card," "bad card" and alarm condition notification outputs are also provided.

The SU3500 has multiple sensors that provide virtually foolproof tracking of users and superior "tailgate" and crawl detection. Safety features include presence sensors, automatic retraction should the wings encounter an object during the closing cycle, and a fire or life safety input.

The turnstile functionality and operational modes can be controlled using Alvarado's optional PC based GateKeeper software. This intuitive application allows virtually all turnstile settings to be changed, as well as all turnstiles to be monitored, from a single PC.

The design of the SU3500 is suitable for any upscale facility. Each unit incorporates a recessed base, attractive satin finished stainless steel cabinet, and lids fabricated from acrylic resin.

Alternative materials and finishes are available, including wood and brass finished cabinets and custom lid materials.



- **Suitable for Upscale Installations**
- **Wings may be Etched with Company Logo**
- **Bi-Directional Control**
- **Easy Installation and Systems Integration**
- **Multi-Lane Cabinet Configurations**
- **ADA Compliant Models**

ALVARADO



# SUPERVISOR 3500

DESCRIPTION

BARRIER WING

# OPTICAL TURNSTILES

alvaradomfg.com

## PRODUCT NAME

Supervisor 3500 - Barrier Wing Optical Turnstile

## APPLICATIONS

Indoor bi-directional optical access control with motorized barrier wings.

## FEATURES

### Electric

- 110 VAC input stepped down and rectified for low voltage 24 VDC, 12 VDC & 5 VDC operation
- Maximum power consumption is 250 watts per lane

### Barrier Wing Modes

- Normal Mode - Wings open to allow passage in authorized directions, otherwise wings remain closed
- Optical Mode - Wings remain open at all times

### Safety

- Fail safe operation opens barrier wings upon loss of power
- Safety sensors prevent wings from closing on personnel or objects

### Inputs

- Separate momentary dry contact inputs are available via terminal strip to activate "passage allowed" and "passage denied" for both directions of operation
- A momentary dry contact input is provided for alarm reset
- Sustained dry contact inputs are available to open or close a turnstile passage direction, select barrier arm mode, or open barrier arms for fire alarm or other life safety system

### Output Signals

- Separate feedback signals are provided for authorized and unauthorized passages, verify, and violation alarms
- Output signals are available via terminal strip as isolated momentary dry contact, allowing integration with remote alarms, electric door locks, CCTV or other devices

### Card Reader / Illuminated Status Display

- Accepts internally mounted small form proximity card readers (customer supplied - contact Alvarado for compatibility guidelines)
- Flush mount turnstile/reader status displays are provided to prompt users for both directions of travel - yellow icon indicates turnstile and reader are ready for card presentation
- Illuminated green arrow icon shows that card has been accepted and passage is allowed
- Red stop icon is illuminated when card has been rejected indicating that passage is denied

### Built-In Violation Alarm

- Unauthorized entries cause a local alarm to sound for adjustable duration ranging from 2 to 8 seconds, or indefinitely until manually reset
- Sensors are able to detect individuals attempting to "tailgate" directly behind an authorized user, or who attempt to crawl through the turnstile
- Alarm also sounds if one or more sensors becomes obstructed

## FEATURES (continued)

### Open / Closed Lights

- Large Green/Red LED indicators flush mounted within cabinet end panels show open/closed status of lanes

### Adjustable Aborted Entry Reset Timer

- Turnstile resets after a "time-out" period if an authorized passage does not occur - time-out period is adjustable

### Adjustable Tailgate Sensitivity

- Allowable minimum distance between users (or objects) passing through the turnstile may be adjusted

## PRODUCT SELECTION

Standard cabinets are stainless steel polished to a #4 satin finish. Recessed base is black satin powder coat. Cabinet lids are constructed from Livingstone™ acrylic resin in Starry Night black. Base units consist of two cabinets. Single expansion cabinets with the same dimensions as a base unit cabinet may be added as needed for multi-lane configurations.

## PRODUCT OPTIONS

**220 VAC** - Unit accepts 220 VAC input.

**Wing Etching** - Customer's choice of logo may be etched on the wings.

**Rejection Beeper** - A beeper indicates that an "unauthorized" card has been presented.

**GateKeeper PC Based Software** - Allows configuration, monitoring and administration of multiple Supervisor Optical Turnstile units from a single PC. Allows automatic lane open/closed scheduling and provides log of all configuration, override and alarm activity.

**Open / Closed Lane Overrides** - Key override installed on turnstile or remotely, allows operators to "open" or "close" one or both directions of passage. Separate overrides required for each direction of passage.

**Alternative Cabinet Materials and Finishes** - Cabinets may be constructed from a variety of fine hardwoods or commonly available laminate materials.

**Alternative Lid Colors and Materials** - Lids may be ordered in alternate colors of Livingstone™ acrylic, as well as natural stone.

## WARRANTY

The Supervisor 3500 is warranted for 18 months from the date of shipment against defects in materials or workmanship.

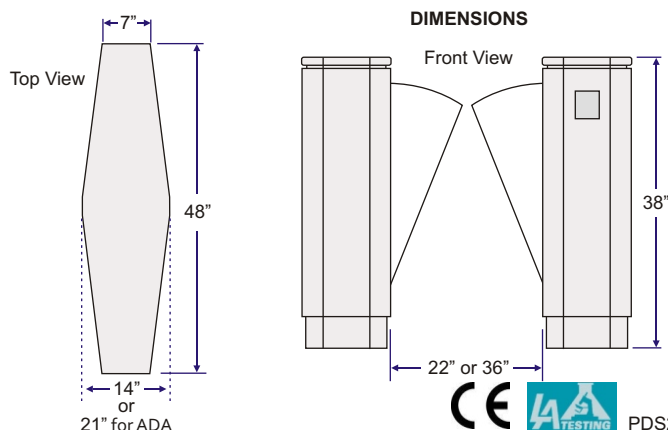

PDS2880R1-6