

MODEL MST

SECURITY TURNSTILES

alvaradomfg.com

Designed for indoor or outdoor access control applications, the MST is the choice of security professionals.

The precision-crafted MST has fully welded roto, yoke and barrier sections, providing superior structural strength and attractive styling. High quality bearings, an investment grade stainless steel mechanism and hardened stainless steel lock arms provide a consistent, smooth rotation and years of trouble free service.

The turnstile is available with manual (MST) or electric (MSTX) operation. Electrically controlled versions have state-of-the-art technology. A rugged multi-fuction

controller, electronic rotation detection, bi-directional interface and time out functionality are all standard on electrically controlled models.

The MST is designed for integration with any identification or access system. The turnstile arrives in four main components and is easily assembled. A large terminal strip interface and field diagnostic tools simplify the process of integrating the unit into a security application.

The MST is available in stainless steel, galvanized and color powder coat finishes. Access card reader attachment plates are available.

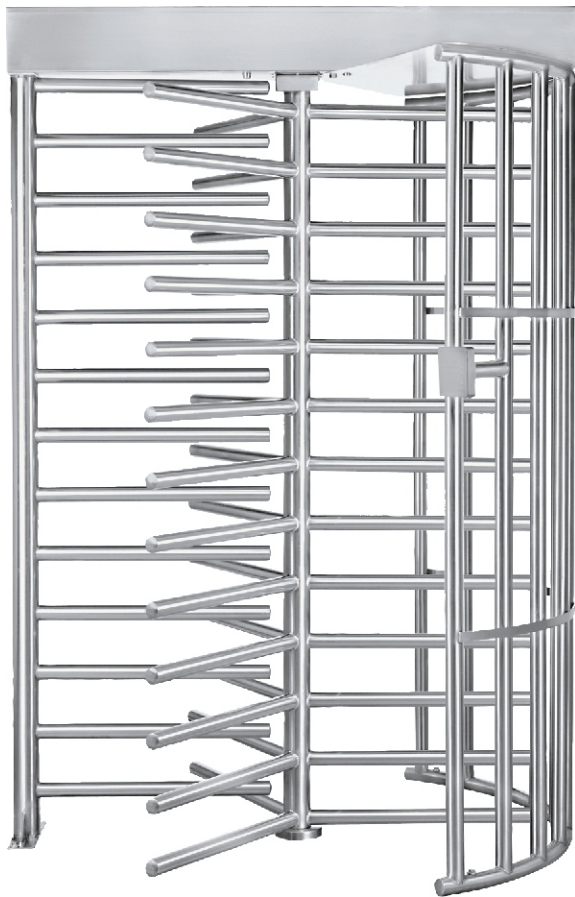

- **Secure Entry/Exit Points**
- **Reduces Staffing Requirements**
- **Fully Welded for Superior Strength**
- **Multi-Function Controller**
- **Easy Installation and Systems Integration**

ALVARADO



PRODUCT NAME

MST full height security turnstile

APPLICATIONS

Manual MST - Provides directional control in a facility requiring an orderly flow of patrons.

Electric MSTX - Provides controlled access to an area requiring access control.

PRODUCT FEATURES - Mechanical

Styling

- Fully welded exterior components
- Top and bottom bearing covers
- Minimal exposed hardware

Materials and Operation

- Stainless steel top channel cover
- Stainless steel investment cast components
- Heavy gauge materials meeting appropriate ASTM standards
- Friction braking for smooth rotation

Finishes

- Galvanized
- Stainless steel polished to a #4 satin finish
- Baked on color powder coat
- Baked on color powder coat over galvanized

Upgrading to Electric Lock Control

- All key lock controlled manual MST-3 top channels are pre-drilled to accept electrical components for easy field upgrade

PRODUCT FEATURES - Electrical

Electric

- 110VAC input stepped down to low voltage 12VDC
- Junction box with dual power receptacle and on/off power switch provided
- Electric turnstiles tested and approved by Los Angeles City Testing Laboratories
- 220VAC units are CE marked

Controller and Access Control Operation

- Electronic rotation detection - no mechanical microswitches required
- Bi-directional interface - an isolated dry contact signal activates the turnstile - no added interface relay required
- Turnstile automatically relocks in 20 seconds if no passage after activation
- Controller provides dry contact rotation signal output to access control provider and/or remote counting system
- Field activation test buttons allow testing of turnstile functionality separate from access system
- "Attendant Override" input accepts dry contact signal to allow attendant to bypass the access control system and unlock the turnstile

PRODUCT SELECTION

MANUAL (MST)

MST-3 - Free rotating in both directions, key lock for both directions.

ELECTRIC (MSTX)

MSTX-5X - Electrically controlled in one direction, free rotating in the opposite direction, self-adjusting speed controlled rotation and automatic self-centering.

MSTX-6X - Electrically controlled in both directions.

MST(X) OPTIONS

Status Lights - Green/red to indicate locked/unlocked status or yellow/green/red to indicate ready status and accept/reject status received from access system.

Fail-Safe Operation - Turnstile provides free rotation upon loss of power in one or both of the electrically controlled directions.

Key Override - Unlocks one or both directions of passage. (Separate override required for each direction.)

Speed Control/Self-Centering - Self adjusting speed controlled rotation and automatic self-centering. (Standard feature with 5X models).

Battery Backup - Provides backup power for electric models.

Adjustable Timed Delay Auto Re-Lock - Allows the duration of time allowed before unit automatically re-locks to be adjusted or disabled in each electrically controlled direction.

Card/Swipe Reader Mounting - Mounting plates for card reader systems.

Remote Locking - Bypasses the access control system and remotely "closes" the unit in the electrically controlled direction(s).

Turnstile Open/Closed Lights - Green/red lights mounted on the turnstile to indicate "open/closed" status. (Used in conjunction with the remote locking and unlocking option.)

220 - 240 Volt Transformer - Replaces standard transformer.

Serial Interface - Allows turnstile to communicate with a PC or controller via RS-232 serial communication.

Heel and Arm Guards - Protective pads available for middle and bottom roto arms.

Custom Options - Custom materials and designs are available to meet your specific requirements.

WARRANTY

Alvarado's one-year written warranty applies to all products.

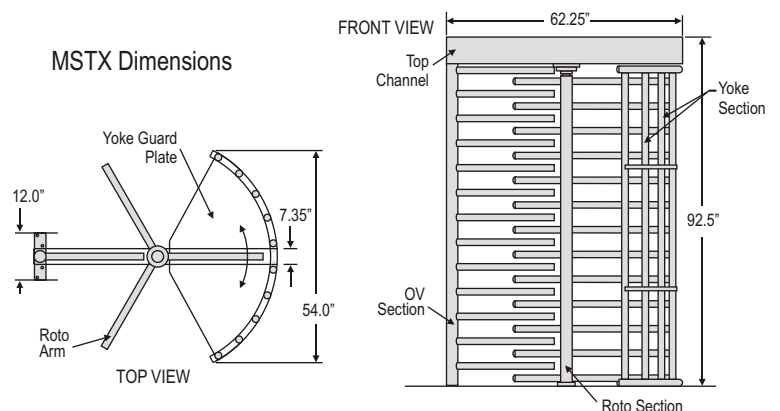

PDS1027R2-3