

MODEL CPST-T

SECURITY TURNSTILES

alvaradomfg.com

Alvarado's CPST-T is the space saving and aesthetically pleasing solution for security in upscale environments.

The CPST-T is the tandem model of our top-of-the-line electrically controlled CPST, offering the functionality of two separate full height security turnstiles, while occupying 30" less installation space.

In addition to its distinctive polycarbonate arms and side enclosure panels, the precision crafted CPST-T includes a fully welded center barrier section to provide superior stability and strength.

High quality bearings, an investment grade stainless steel mechanism and hardened stainless steel lock arms ensure a consistent, smooth

rotation and years of trouble free service.

CPST-T turnstiles offer the same state-of-the-art technology found in our MSTX turnstiles. Standard features include a rugged multi-function controller, electronic rotation detection, bi-directional interface and time out functionality.

The turnstile arrives in six main components and is easily assembled. A large terminal strip interface and field diagnostic tools simplify integration of the unit into any identification or access system.

The CPST-T comes in satin stainless steel or powder coat finishes. The side enclosure panel frames are brushed aluminum. Access control card reader attachment plates are available.



Note: CPST with custom flat bar OV shown. Standard OV fabricated from round tubing.

- ***Inexpensive Alternative to a Secured Revolving Door***
- ***30" Narrower than Two Standard Units***
- ***Scratch-Resistant Polycarbonate Arms***
- ***Curved Polycarbonate Yoke Sections***
- ***Easy Installation and Systems Integration***

ALVARADO

Protecting assets and controlling the flow of people



PRODUCT NAME

CPST-T tandem full height security turnstile

APPLICATIONS

Provides controlled access for areas that need two full height turnstiles, but require a smaller installation footprint.

PRODUCT FEATURES - Mechanical

Styling

- Clear polycarbonate arms
- Curved two-piece polycarbonate yoke sections
- Top and bottom bearing covers
- Minimal exposed hardware
- Fully welded barrier section

Materials and Operation

- Stainless steel top channel cover
- Stainless steel investment cast components
- Polycarbonate yokes and turnstile arms have scratch resistant coating
- Laminated polycarbonate arms provide superior strength
- Friction braking for smooth rotation

Finishes

- Stainless steel polished to a #4 satin finish
- Baked on color powder coat

PRODUCT FEATURES - Electrical

Electric

- 110VAC input stepped down to low voltage 12VDC
- Junction boxes with dual power receptacles and on/off power switches provided
- Electric turnstiles tested and approved by Los Angeles City Testing Laboratories
- 220VAC units are CE marked

Controller and Access Control Operation

- Electronic rotation detection - no mechanical microswitches required
- Bi-directional interface - an isolated dry contact signal activates the turnstile - no added interface relay required
- Turnstile automatically relocks in 20 seconds if no passage after activation
- Controller provides dry contact rotation signal output to access control provider and/or remote counting system
- Field activation test buttons allow testing of turnstile functionality separate from access system
- "Attendant Override" input accepts dry contact signal to allow attendant to bypass the access control system and unlock the turnstile

PRODUCT SELECTION

CPST-TX-5X - Each roto electrically controlled in one direction, free rotating in the opposite direction, self-adjusting speed controlled rotation and automatic self-centering.

CPST-TX-6X - Each roto electrically controlled in both directions.

OPTIONS

Status Lights - Green/red to indicate locked/unlocked status or yellow/green/red to indicate ready status and accept/reject status received from access system.

Fail-Safe Operation - Turnstile provides free rotation upon loss of power in one or both of the electrically controlled directions.

Key Override - Unlocks some or all directions of passage (Separate override required for each direction).

Speed Control/Self-Centering - Self adjusting speed controlled rotation and automatic self-centering. (Standard feature with 5X models).

Battery Backup - Battery backup system allows continued operation during a loss of primary power.

Adjustable Timed Delay Auto Re-Lock - Allows the duration of time allowed before unit automatically re-locks to be adjusted or disabled in each electrically controlled direction.

Card/Swipe Reader Mounting - Mounting plates for card reader systems.

Remote Locking - Bypasses the access control system and remotely "closes" the unit in the electrically controlled direction(s).

Turnstile Open/Closed Lights - Green/red lights mounted on the turnstile top channel to indicate "open/closed" status (Used in conjunction with remote locking/unlocking option).

220 - 240 Volt Transformer - Replaces standard transformer.

Serial Interface - Allows turnstile to communicate with a PC or controller via RS-232 serial communication.

Custom Options - Custom materials and designs are available to meet your specific requirements.

WARRANTY

Alvarado's one-year written warranty applies to all products.

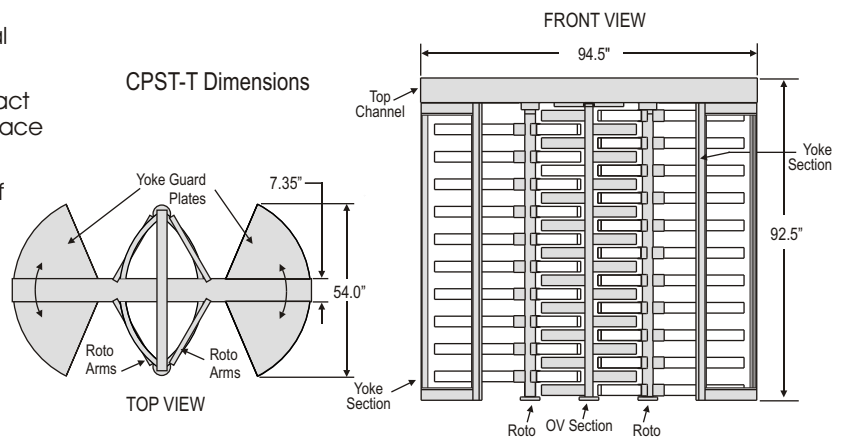

PDS1030R2-2