

MODEL CLST-T

SECURITY TURNSTILES

alvaradomfg.com

Alvarado's CLST-T is an attractive, space saving solution for high security access control applications.

The tandem model CLST-T offers the functionality of two separate full height turnstiles, while occupying 30" less installation space.

The CLST-T features fully welded center barrier and roto sections, plus distinctive polycarbonate side enclosure panels to provide superior structural strength and unique styling.

High quality bearings, an investment grade stainless steel mechanism and hardened stainless steel lock arms ensure a consistent, smooth rotation and years of trouble free service.

CLST-T turnstiles offer the same state-of-the-art technology found in our MSTX turnstiles. Standard features include a rugged multi-function controller, electronic rotation detection, bi-directional interface and time out functionality.

The turnstile arrives in six main components and is easily assembled. A large terminal strip interface and field diagnostic tools simplify integration of the unit into any identification or access system.

The CLST-T is available in satin stainless steel or powder coat finishes. The side enclosure panel frames are brushed aluminum. Access control card reader attachment plates are available.

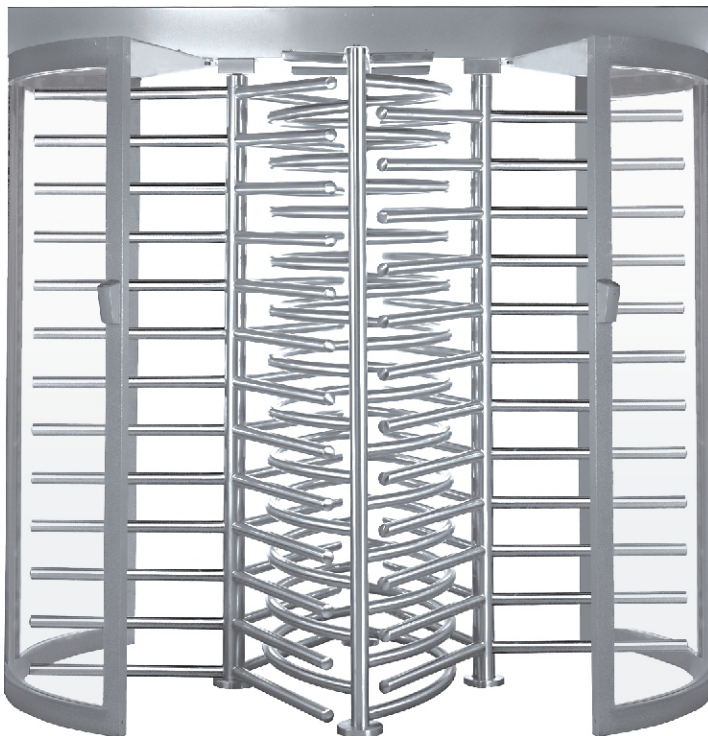

- **Secures Entry/Exit Points**
- **Curved Polycarbonate Yoke Sections**
- **30" Narrower than Two Standard Units**
- **Reduces Staffing Requirements**
- **Fully Welded Roto and Center OV for Superior Strength**
- **Easy Installation and Systems Integration**

ALVARADO



PRODUCT NAME

CLST-T tandem full height security turnstile

APPLICATIONS

Provides controlled access for areas that need two full height turnstiles, but require a smaller installation footprint.

PRODUCT FEATURES - Mechanical

Styling

- Fully welded roto sections
- Fully welded barrier section
- Curved two-piece polycarbonate yoke sections
- Top and bottom bearing covers
- Minimal exposed hardware

Materials and Operation

- Stainless steel top channel cover
- Stainless steel investment cast components
- Heavy gauge materials meeting appropriate ASTM standards
- Yoke sections have scratch resistant coating
- Friction braking for smooth rotation

Finishes

- Stainless steel polished to a #4 satin finish
- Baked on color powder coat

PRODUCT FEATURES - Electrical

Electric

- 110VAC input stepped down to low voltage 12VDC
- Junction boxes with dual power receptacles and on/off power switches provided
- Electric turnstiles tested and approved by Los Angeles City Testing Laboratories
- 220VAC units are CE marked

Controller and Access Control Operation

- Electronic rotation detection - no mechanical micro switches required
- Bi-directional interface - an isolated dry contact signal activates the turnstile - no added interface relay required
- Turnstile automatically relocks in 20 seconds if no passage after activation
- Controller provides dry contact rotation signal output to access control provider and/or remote counting system
- Field activation test buttons allow testing of turnstile functionality separate from access system
- "Attendant Override" input accepts dry contact signal to allow attendant to bypass the access control system and unlock the turnstile

PRODUCT SELECTION

CLST-TX-5X - Each roto electrically controlled in one direction, free rotating in the opposite direction, self-adjusting speed controlled rotation and automatic self-centering.

CLST-TX-6X - Each roto electrically controlled in both directions.

OPTIONS

Status Lights - Green/red to indicate locked/unlocked status or yellow/green/red to indicate ready status and accept/reject status received from access system.

Fail-Safe Operation - Turnstile provides free rotation upon loss of power in one or both of the electrically controlled directions.

Key Override - Unlocks some or all directions of passage (Separate override required for each direction).

Speed Control/Self-Centering - Self adjusting speed controlled rotation and automatic self-centering. (Standard feature with 5X models).

Battery Backup - Battery backup system allows continued operation during a loss of primary power.

Adjustable Timed Delay Auto Re-Lock - Allows the duration of time allowed before unit automatically re-locks to be adjusted or disabled in each electrically controlled direction.

Card/Swipe Reader Mounting - Mounting plates for card reader systems.

Remote Locking - Bypasses the access control system and remotely "closes" the unit in the electrically controlled direction(s).

Turnstile Open/Closed Lights - Green/red lights mounted on the turnstile top channel to indicate "open/closed" status (Used in conjunction with the remote locking and unlocking option).

220 - 240 Volt Transformer - Replaces standard transformer.

Serial Interface - Allows turnstile to communicate with a PC or controller via RS-232 serial communication.

Heel and Arm Guards - Protective pads available for middle and bottom roto arms.

Custom Options - Custom materials and designs are available to meet your specific requirements.

WARRANTY

Alvarado's one-year written warranty applies to all products.

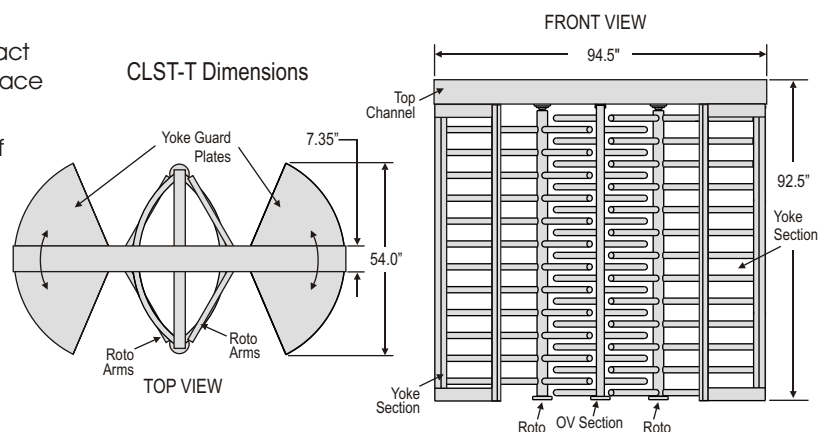

PDS1032R2-2