

MODEL CLST

SECURITY TURNSTILES

alvaradomfg.com

Alvarado's CLST is an attractive alternative for security access control applications.

The precision-crafted CLST features fully welded roto and barrier sections, plus an attractive polycarbonate side enclosure panel. High quality bearings, an investment grade stainless steel mechanism and hardened stainless steel lock arms ensure a consistent, smooth rotation and years of trouble free service.

The turnstile is available with manual (CLST) or electric (CLSTX) operation. Electrically controlled versions use the same state-of-the-art technology found in Alvarado's MSTX turnstiles. A rugged multi-function controller, electronic rotation detection,

bi-directional interface and time out functionality are all standard on electrically controlled models.

The CLST is designed for integration with any identification or access system. The turnstile arrives in four main components and is easily assembled. A large terminal strip interface and field diagnostic tools simplify the process of integrating the unit into a security application.

CLST turnstiles can be ordered in stainless steel or powder coat finishes. Card reader attachment plates are available.

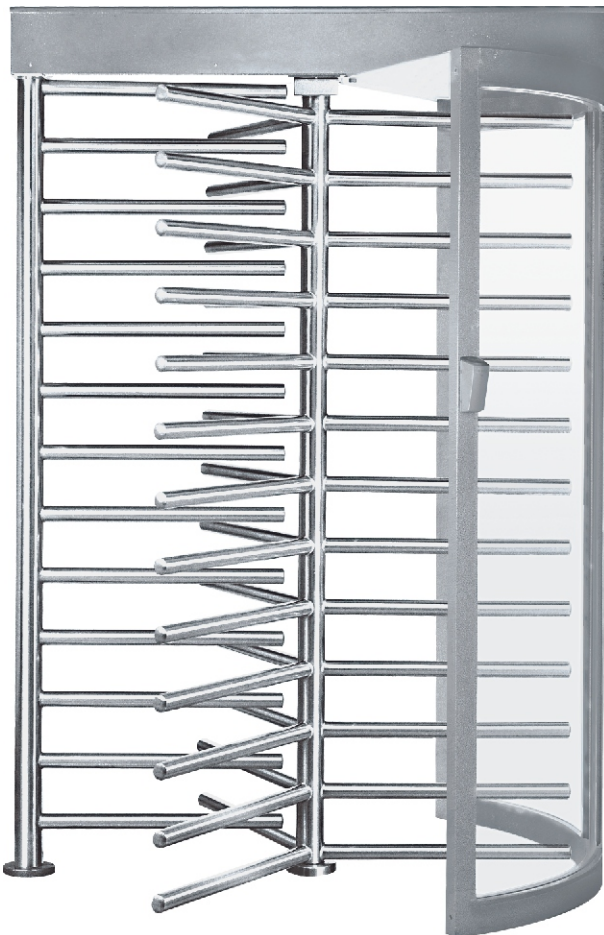

- **Secures Entry/Exit Points**
- **Reduces Staffing Requirements**
- **Attractive Curved Polycarbonate Enclosure Panel**
- **Easy Installation and Systems Integration**
- **Fully Welded Roto Provides Superior Strength**
- **Multi-Function Controller**

ALVARADO



PRODUCT NAME

CLST full height security turnstile

APPLICATIONS

Manual CLST - Provides directional control in a facility requiring an orderly flow of patrons.

Electric CLSTX - Provides controlled access to an area requiring access control.

PRODUCT FEATURES - Mechanical

Styling

- Fully welded roto and barrier sections
- Curved two-piece polycarbonate yoke section
- Top and bottom bearing covers
- Minimal exposed hardware

Materials and Operation

- Stainless steel top channel cover
- Stainless steel investment cast components
- Polycarbonate yoke has scratch resistant coating
- Heavy gauge materials meeting appropriate ASTM standards
- Friction braking for smooth rotation

Finishes

- Stainless steel polished to a #4 satin finish
- Baked on color powder coat

Upgrading to Electric Lock Control

- All manual CLST top channels are pre-drilled to accept electrical components for easy field upgrade

PRODUCT FEATURES - Electrical

Electric

- 110VAC input stepped down to low voltage 12VDC
- Junction box with dual power receptacle and on/off power switch provided
- Electric turnstiles tested and approved by Los Angeles City Testing Laboratories
- 220VAC units are CE marked

Controller and Access Control Operation

- Electronic rotation detection - no mechanical microswitches required
- Bi-directional interface - an isolated dry contact signal activates the turnstile - no added interface relay required
- Turnstile automatically relocks in 20 seconds if no passage after activation
- Controller provides dry contact rotation signal output to access control provider and/or remote counting system
- Field activation test buttons allow testing of turnstile functionality separate from access system
- "Attendant Override" input accepts dry contact signal to allow attendant to bypass the access control system and unlock the turnstile

PRODUCT SELECTION

MANUAL (CLST)

CLST-3 - Free rotating in both directions, key lock for both directions.

ELECTRIC (CLSTX)

CLSTX-5X - Electrically controlled in one direction, free rotating in the opposite direction, self-adjusting speed controlled rotation and automatic self-centering.

CLSTX-6X - Electrically controlled in both directions.

CLST(X) OPTIONS

Status Lights - Green/red to indicate locked/unlocked status or yellow/green/red to indicate ready status and accept/reject status received from access system.

Fail-Safe Operation - Turnstile provides free rotation upon loss of power in one or both of the electrically controlled directions.

Key Override - Unlocks one or both directions of passage (Separate override required for each direction).

Speed Control/Self-Centering - Self-adjusting speed controlled rotation and automatic self-centering. (Standard feature with 5X models).

Battery Backup - Provides backup power for electric models.

Adjustable Timed Delay Auto Re-Lock - Allows the duration of time allowed before unit automatically re-locks to be adjusted or disabled in each electrically controlled direction.

Card/Swipe Reader Mounting - Mounting plates for card reader systems.

Remote Locking - Bypasses the access control system and remotely "closes" the unit in the electrically controlled direction(s).

Turnstile Open/Closed Lights - Green/red lights mounted on the turnstile top channel to indicate "open/closed" status (Used in conjunction with the remote locking and unlocking option).

220 - 240 Volt Transformer - Replaces standard transformer.

Serial Interface - Allows turnstile to communicate with a PC or controller via RS-232 serial communication.

Heel and Arm Guards - Protective pads available for middle and bottom roto arms.

Custom Options - Custom materials and designs are available to meet your specific requirements.

WARRANTY

Alvarado's one-year written warranty applies to all products.

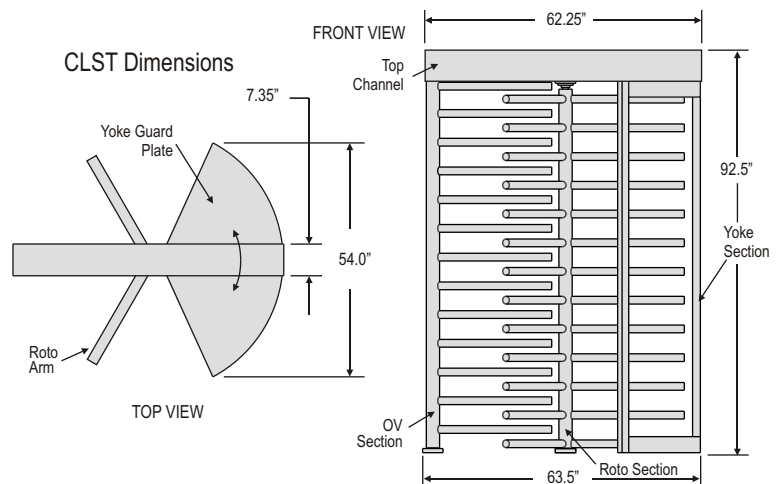

PDS1031R2-3